



**3D FOR VET**

STRATEGIC PARTNERSHIP FOR THE  
DEVELOPMENT OF 3D COMPETENCES

# **Student workshop: Animal cell**

The European Commission's support for the production of this publication does not constitute an endorsement of the contents, which reflect the views only of the authors, and the Commission cannot be held responsible for any use which may be made of the information contained therein.



Erasmus+

# Contribution

## Responsible partner

- Metris Research Centre, Croatia

## Coordination

- Region of Istria, Croatia
- Regional Coordinator for European Programmes and Funds of the Region of Istria, Croatia

## Task Force / Project Partners

- Regional Coordinator for European Programmes and Funds of the Region of Istria, Croatia
- Carinthia University of Applied Sciences, Austria
- Pula Technical School, Croatia
- Metris Research Centre, Croatia
- Malopolska Voivodship, Poland
- Public Institution Panevėžys Vocational Education and Training Centre, Lithuania
- Jan Pawel II's School Miechow, Poland



# Student workshop: Animal cell

## *Workshop info*

<b>Subject:</b>	Biology
<b>Grades:</b>	1 <sup>st</sup> - 2 <sup>nd</sup> class of high school
<b>Class size:</b>	10 to 16 students / 2 to 3 students per group
<b>Duration:</b>	1 day intro into 3D printing, 1 day of preparation of models, 1 day of workshop
<b>Skills needed:</b>	None

## *References and models*

- <https://www.thingiverse.com/thing:2485063>



## *Needed materials*

In addition to a computer and a fused deposition 3D printer with the associated software, the following materials are needed for the workshop:

- FreeCAD (free and open-source CAD modeler or a similar program)
- available models

## *Learning objective*

An animal cell is a type of eukaryotic cell and a great example of how to get students interested in the field of biology, that is, to learn the basics about the structure of an animal cell. The students will work together in small groups to model, build and assemble the essential parts of an animal cell and learn more about the topic through hands-on work.

Parts of the animal eukaryotic cell are made on 3D printers. Students are introduced to the basics of 3D printing (introductory lesson), how the production process works and the differences in printing processes. They will also learn to work independently with the printer and related software to properly print parts of an animal cell model.

## *Basics of 3D printing (introductory lesson unit)*

The teacher explains to the students how a 3D printer works, which types of printer they have, and how to handle the machine.

Some keywords the teacher should mention/explain:

- Printing process
- Layer height
- Infill / Infill Pattern
- File format
- Shell / Layer
- Design rules
- Support
- Slicer
- Raft
- Errors

## *Lesson plan and activities*

### *1. Teacher preparations*

Each group of students should have a basic 3D model of the basic elements of the animal cell before they begin the process of selecting the necessary parameters for 3D printing.

**TIP:** Print individual elements of the animal cell with material in different colors and, if necessary, without supporting material, lying flat on the work platform.

## Print settings

Raft	Yes
Support	No
Nozzle diameter	0.4 mm
Layer	0.19 mm
Infill	30%

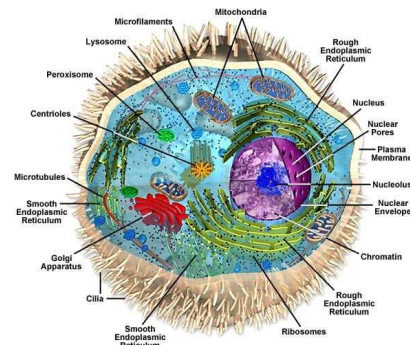

## Model examples:

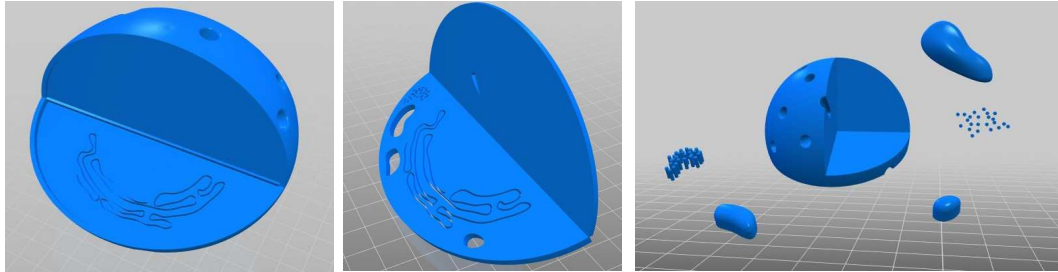

## 2. Basic structure of an animal cell

The teacher explains to the students the basic elements and function of the individual parts of the animal cell.

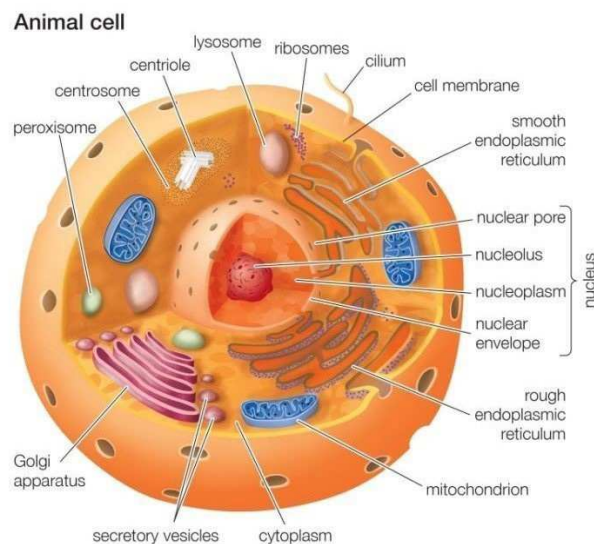

## 3. Demonstration and description

Animal cells are eukaryotic cells, sealed by a plasma membrane and contain a nucleus and organelles bound to the membrane. Unlike plant and fungal eukaryotic cells, animal cells do not have a cell wall. Most cells, both animal and plant, range from 1 to 100 micrometers and are thus visible only with the aid of a microscope.

Animals are a large and incredibly diverse group of organisms. Animals are capable of sensing and responding to their environment, they have the flexibility to embrace different feeding, defense, and reproduction modes. However, unlike plants, animals are not able to produce their own food and therefore are always directly or indirectly dependent on plant life.

Most animal cells are diploid, meaning that their chromosomes exist in homologous pairs. However, various chromosomal ploidy are also known to occasionally occur.

The basic structure of the animal cell consists of: centrioles, cilia and flagella, endoplasmic reticulum, endosomes and endocytosis, Golgi apparatus, intermediate filaments, lysosomes, microfilaments, microtubules, mitochondria, nucleus (nucleus), peroxisomes, plasma membrane and ribosomes.

#### 4. Test of the assembly designs

Students must assemble the basic unit of the animal cell from an example and parts already available to them.



#### 5. Evaluate and review

Each group presents an elaborate example of an animal cell. Discuss what all biology topics and models can be crafted this way. What factors affect how an animal cell is modeled. How can we improve, change or create our own animal cell model design.

#### 6. Modification of the original printing settings and testing of the new parts

In groups, students discuss which print settings they want to change and what impact on the printed object will it have. The modified parts were printed out and tested by the students. The modified print settings are for example to decrease the layer height from 0.19 mm to 0.14 mm to get a smoother surface. Know that this will increase the printing time. The infill is another parameter that the students can modify. They can change it from the recommended 30% to 10% or 50%. Use a scale to measure the weight difference of the new parts.

**TIP:** Modify printing setting one by one to see the effect. Keep in mind that a lower infill and number of slides will reduce the weight but also reduce the stability.

#### 7. Evaluate and review the modified parts and whole animal cell

Each group calculates and evaluates the main printing parameters such as: layer thickness, printing time, infill, layer height and other printing process characteristics. Discuss which parameters have the major impact for achieving the stability of the object. Determine if the expected results occurred.

## 8. Advanced part - designing and building new modified parts of animal cell or the whole cell

The next part of the workshop is that the students design and build their own designs of the animal cell and different cell parts.

For that, the students model their own designs by using the knowledge they got through the workshop, the discussions and test of the animal cell parts and shapes. They have two possible options. The first one is to modify the existing design. The second option is to create a complete new design. The groups can decide which options they want to choose and begin planning their design.

### Different examples:

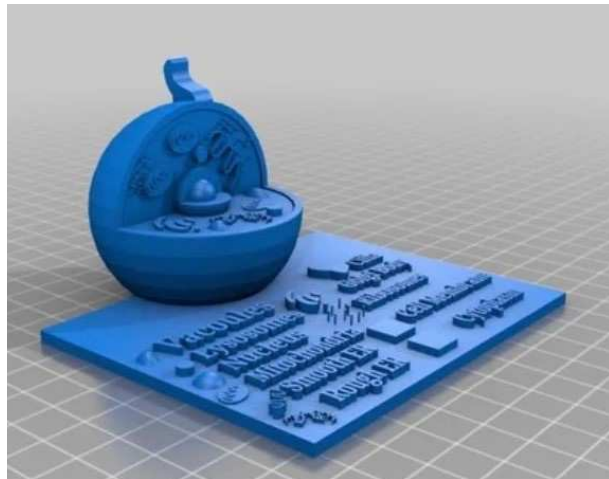

## 9. Evaluation and review of the modified design

The students print their self-made designs and test them. Determine if the changes/improvements helped as expected.

## 10. Reflections

What animal cell designs were the most efficient and what common design links do they have?

What's the most important thing you learned today? Why do you think so?

Would you use 3D printing for further projects?

What do you want to learn more about, and why?

Reflect on your thinking, learning, and work today. What were you most proud of?



**3D FOR VET**

STRATEGIC PARTNERSHIP FOR THE  
DEVELOPMENT OF 3D COMPETENCES

# **Student workshop: Plant cell**

The European Commission's support for the production of this publication does not constitute an endorsement of the contents, which reflect the views only of the authors, and the Commission cannot be held responsible for any use which may be made of the information contained therein.



Erasmus+



# Contribution

## Responsible partner

- Metris Research Centre, Croatia

## Coordination

- Region of Istria, Croatia
- Regional Coordinator for European Programmes and Funds of the Region of Istria, Croatia

## Task Force / Project Partners

- Regional Coordinator for European Programmes and Funds of the Region of Istria, Croatia
- Carinthia University of Applied Sciences, Austria
- Pula Technical School, Croatia
- Metris Research Centre, Croatia
- Malopolska Voivodship, Poland
- Public Institution Panevėžys Vocational Education and Training Centre, Lithuania
- Jan Pawel II's School Miechow, Poland



# Student workshop: Plant cell

## *Workshop info*

<b>Subject:</b>	Biology
<b>Grades:</b>	1 <sup>st</sup> - 2 <sup>nd</sup> class of high school
<b>Class size:</b>	10 to 16 students / 2 to 3 students per group
<b>Duration:</b>	1 day intro into 3D printing, 1 day of preparation of models, 1 day of workshop
<b>Skills needed:</b>	None

## *References and models*

- <https://www.thingiverse.com/thing:2811554>



## *Needed materials*

In addition to a computer and a fused deposition 3D printer with the associated software, the following materials are needed for the workshop:

- FreeCAD (free and open-source CAD modeler or a similar program)
- available models

## *Learning objective*

Plant cell is a type of eukaryotic cell and is a great example of how students can get interested in the field of biology, that is, to learn the basics about the structure of a plant cell. The students will work together in small groups to model, build and assemble the essential parts of a plant cell and learn more about the topic through hands-on work.

Parts of the plant eukaryotic cell are made on 3D printers. Students are introduced to the basics of 3D printing (introductory lesson), how the production process works and the differences in printing processes. They will also learn to work independently with the printer and related software to properly print parts of plant station model.

## *Basics of 3D printing (introductory lesson unit)*

The teacher explains to the students how a 3D printer works, which types of printer they have, and how to handle the machine.

Some keywords the teacher should mention/explain:

- Printing process
- Layer height
- Infill / Infill Pattern
- File format
- Shell / Layer
- Design rules
- Support
- Slicer
- Raft
- Errors

## *Lesson plan and activities*

### *1. Teacher preparations*

Each group of students should have a basic 3D model of the basic elements of the plant cell before they begin the process of selecting the necessary parameters for 3D printing.

**TIP:** Print individual elements of the plant cell with material in different colors and, if necessary, without supporting material, lying flat on the work platform.

### Print settings

Raft	Yes
Support	No
Nozzle diameter	0.4 mm
Layer	0.19 mm
Infill	30%

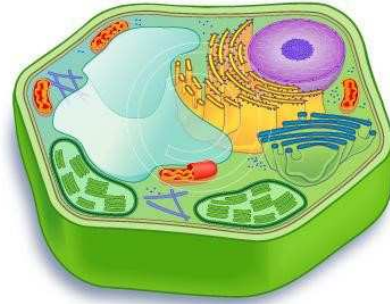

### Model examples:

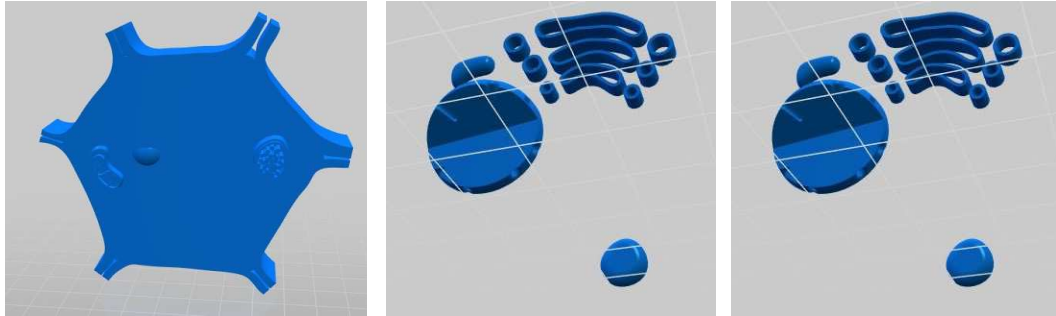

## 2. Basic structure of a plant cell

The teacher explains to the students the basic elements and function of the individual parts of the plant cell.

# PLANT CELL

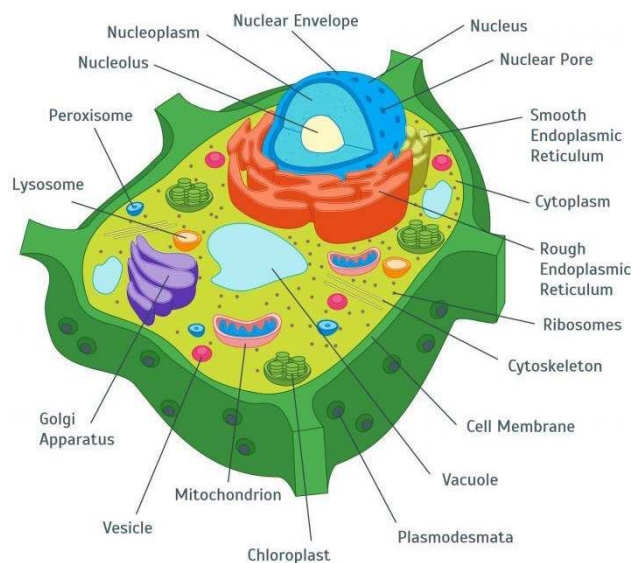

## 3. Demonstration and description

The plant cell consists of a cell wall and a protoplast. Protoplasts include protoplasts that incorporate vacuoles, organelles, membrane systems, macromolecular clusters. The cell wall is a permeable, yet solid structure that protects the cell and gives it a permanent shape. The primary cell wall is made of cellulose filaments, which are placed at right angles to each other to increase their strength. The secondary cell wall may be located within the primary cell and is

made of lignin, a substance that further enhances the cell wall. A large central vacuole full of water and colloids allows the maintenance of turgor pressure and serves as a unique organelle for storing and acting out metabolic processes. The plant cell has plastids, the most important of which is chloroplast, the organelles found in the cytoplasm, possessing pigments such as chlorophylls and carotenoids, and is the site of food synthesis and storage. The chloroplast contains chlorophyll and uses light energy to convert carbon dioxide and water into carbohydrates and oxygen, ie chloroplast is the site of photosynthesis.

In plant cells, three basic types of cytoskeletal elements are encountered: actin filaments, microtubules, and intermediate filaments. The actin filaments are arranged in a band, which more or less divides the cytoplasm into two parts - one stationary to the cell membrane and one fluid to the vacuole. In this fluid portion of the cytoplasm, organelle movements occur through actin filaments and cytoplasmic flow.

The microtubules were lined up along the cell membrane, in bundles. They play a role in organizing the cellulose synthetase complex, allowing the formation of parallel cellulose fibrils in the cell wall. The direction of provision of cellulose fibrils follows the direction of provision of microtubules. Intermediate filaments are rarely present, represented by filaments that position the tonoplast and nucleus to the cell, allowing mechanical resistance to the pressure of the vacuole on the cytoplasm.

#### 4. Test of the assembly designs

Students must assemble the four basic unit of the plant cell from an example and parts already available to them.

#### 5. Evaluate and review

Each group presents an elaborate example of the plant cell. Discuss what all biology topics and models can be crafted this way. What factors affect how plant cell is modeled. How can we improve, change or create our own plant cell model design.



## 6. Modification of the original printing settings and testing of the new parts

In groups, students discuss which print settings they want to change and what impact on the printed object will it have. The modified parts were printed out and tested by the students. The modified print settings are for example to decrease the layer height from 0.19 mm to 0.14 mm to get a smoother surface. Know that this will increase the printing time. The infill is another parameter that the students can modify. They can change it from the recommended 30% to 10% or 50%. Use a scale to measure the weight difference of the new parts.

**TIP:** Modify printing setting one by one to see the effect. Keep in mind that a lower infill and number of slides will reduce the weight but also reduce the stability.

## 7. Evaluate and review the modified parts and whole plant cell

Each group calculates and evaluates the main printing parameters such as: layer thickness, printing time, infill, layer height and other printing process characteristics. Discuss which parameters have the major impact for achieving the stability of the object. Determine if the expected results occurred.

## 8. Advanced part - designing and building new modified parts of plant cell or the whole cell

The next part of the workshop is that the students design and build their own designs of the plant cell and different cell parts.

For that, the students model their own designs by using the knowledge they got through the workshop, the discussions and test of the plant cell parts and shapes. They have two possible options. The first one is to modify the existing design. The second option is to create a complete new design. The groups can decide which options they want to choose and begin planning their design.

### Different examples:



### 9. Evaluation and review of the modified design

The students print their self-made designs and test them. Determine if the changes/improvements helped as expected.

### 10. Reflections

What plant cell designs were the most efficient and what common design links do they have?

What's the most important thing you learned today? Why do you think so?

Would you use 3D printing for further projects?

What do you want to learn more about, and why?

Reflect on your thinking, learning, and work today. What were you most proud of?



## 3D FOR VET

STRATEGIC PARTNERSHIP FOR THE  
DEVELOPMENT OF 3D COMPETENCES

# Student workshop: Phone stand

The European Commission's support for the production of this publication does not constitute an endorsement of the contents, which reflect the views only of the authors, and the Commission cannot be held responsible for any use which may be made of the information contained therein.



Erasmus+



# Contribution

## Responsible partner

- Metris Research Centre, Croatia

## Coordination

- Region of Istria, Croatia
- Regional Coordinator for European Programmes and Funds of the Region of Istria, Croatia

## Task Force / Project Partners

- Regional Coordinator for European Programmes and Funds of the Region of Istria, Croatia
- Carinthia University of Applied Sciences, Austria
- Pula Technical School, Croatia
- Metris Research Centre, Croatia
- Malopolska Voivodship, Poland
- Public Institution Panevėžys Vocational Education and Training Centre, Lithuania
- Jan Pawel II's School Miechow, Poland



# Student workshop: Phone stand

## *Workshop info*

<b>Subject:</b>	Engineering
<b>Grades:</b>	1 <sup>st</sup> – 2 <sup>nd</sup> class of high school
<b>Class size:</b>	10 to 16 students / 3 to 4 students per group
<b>Duration:</b>	1 day intro into 3D printing, 1 day of workshop
<b>Skills needed:</b>	None

## *References and models*

- <https://cults3d.com/en/3d-model/gadget/mechanical-quick-grab-release-phone-stand>



## *Needed materials*

In addition to a computer and a fused deposition 3D printer with the associated software, the following materials are needed for the workshop:

- FreeCAD (free and open-source CAD modeler or a similar program)
- small spring
- available models

## Learning objective

This is an example of representative technical design and is very functional. This stand allows for multiple viewing angles, and best of all, it has a quick-catch/release mechanism that catches and locks the phone when you release it and releases the phone when you pick up the phone.

The stand can be made on 3D printers. Students are introduced to the basics of 3D printing, how the production process works and the difference between the printing processes. They learn to work independently with the printer and the associated software for printing a mobile phone stand model.

## Basics of 3D printing (introductory lesson unit)

The teacher explains to the students how a 3D printer works, which types of printer they have, and how to handle the machine.

Some keywords the teacher should mention/explain:

- Printing process
- Layer height
- Infill / Infill Pattern
- File format
- Shell / Layer
- Design rules
- Support
- Slicer
- Raft
- Errors



## Lesson plan and activities

### 1. Teacher preparations

Each group of students should have a basic 3D model of all the components of a mobile phone stand before beginning the process of selecting the necessary parameters for 3D printing.

**TIP:** Print the moving parts of the mechanism in one color (e.g. orange) and the other parts of the stand in black and, if necessary, without supporting material, lying flat on the work platform (panel).

### Print settings

Raft	Yes
Support	No
Nozzle diameter	0.4 mm
Layer	0.19 mm
Infill	20%

## 2. Basic structure of the phone stand

The teacher explains to the students the basic parts and functioning of individual parts of the phone stand.

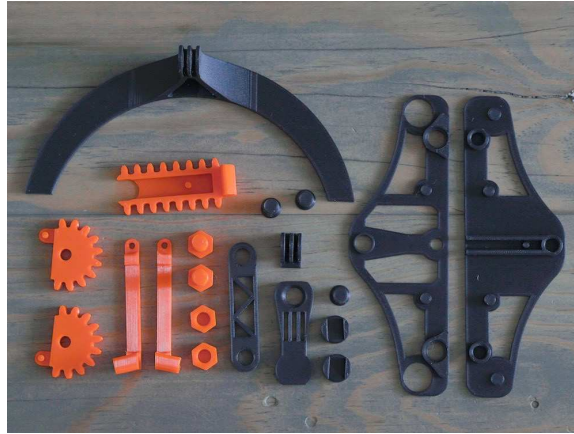

## 3. Test of the assembly designs

Students must assemble the basic unit of the stand into a functional unit.



## 4. Evaluate and review

Each group presents an elaborate example of a stand. Discuss what all engineering topics and models can be crafted this way. What factors affect how a phone stand is modeled. How can we improve, change or create our own phone stand model design.

## 5. Modification of the original printing settings and testing of the new parts

In groups, students discuss which print settings they want to change and what impact on the printed object will it have. The modified parts were printed out and tested by the students. The modified print settings are for example to decrease the layer height from 0.19 mm to 0.14 mm to get a smoother surface. Know that this will increase the printing time. The infill is another parameter that the students can modify. They can change it from the recommended 20% to 10% or 50%. Use a scale to measure the weight difference of the new parts.

**TIP:** Modify printing setting one by one to see the effect. Keep in mind that a lower infill and number of slides will reduce the weight but also reduce the stability.

## 6. Evaluate and review the modified parts and whole phone stand

Each group calculates and evaluates the main printing parameters such as: layer thickness, printing time, infill, layer height and other printing process characteristics. Discuss which parameters have the major impact for achieving the stability of the object. Determine if the expected results occurred.

## 7. Advanced part - designing and building new modified parts of the phone stand or the whole unit

The next part of the workshop is that the students design and build their own designs of the phone stand and different phone stand unit parts. For that, the students model their own designs by using the knowledge they got through the workshop, the discussions and test of the stand parts and shapes. They have two possible options. The first one is to modify the existing design. The second option is to create a complete new design. The groups can decide which options they want to choose and begin planning their design.

### Different examples:

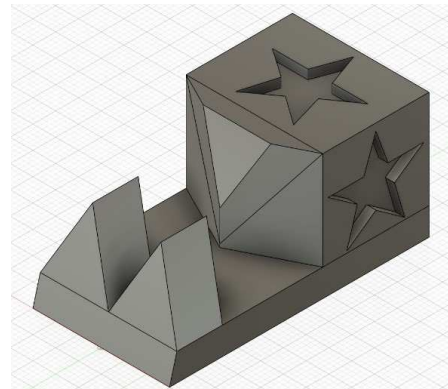
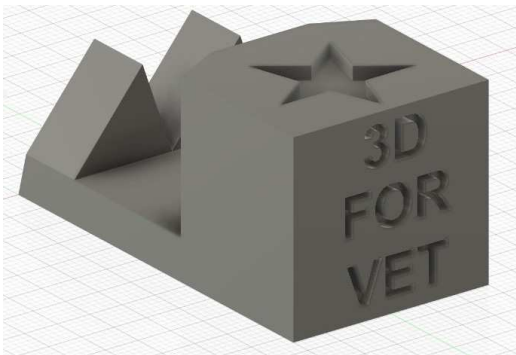

## 8. Evaluation and review of the modified design

The students print their self-made designs and test them. Determine if the changes/improvements helped as expected.

## 9. Reflections

What phone stand designs were the most efficient and what common design links do they have?

What's the most important thing you learned today? Why do you think so?

Would you use 3D printing for further projects?

What do you want to learn more about, and why?

Reflect on your thinking, learning, and work today. What were you most proud of?



**3D FOR VET**

STRATEGIC PARTNERSHIP FOR THE  
DEVELOPMENT OF 3D COMPETENCES

# **Student workshop: Spirograph**

The European Commission's support for the production of this publication does not constitute an endorsement of the contents, which reflect the views only of the authors, and the Commission cannot be held responsible for any use which may be made of the information contained therein.



Erasmus+

# Contribution

## Responsible partner

- Metris Research Centre, Croatia

## Coordination

- Region of Istria, Croatia
- Regional Coordinator for European Programmes and Funds of the Region of Istria, Croatia

## Task Force / Project Partners

- Regional Coordinator for European Programmes and Funds of the Region of Istria, Croatia
- Carinthia University of Applied Sciences, Austria
- Pula Technical School, Croatia
- Metris Research Centre, Croatia
- Malopolska Voivodship, Poland
- Public Institution Panevėžys Vocational Education and Training Centre, Lithuania
- Jan Pawel II's School Miechow, Poland



# Student workshop: Spirograph

## Workshop info

Subject:	Engineering, Science, Math
Grades:	1 <sup>th</sup> - 4 <sup>th</sup> class of high school
Class size:	10 to 16 students / 2 to 3 students per group
Duration:	1 day intro into 3D printing, 1 day of workshop
Skills needed:	None

## References and models

- <https://www.thingiverse.com/thing:2878811>

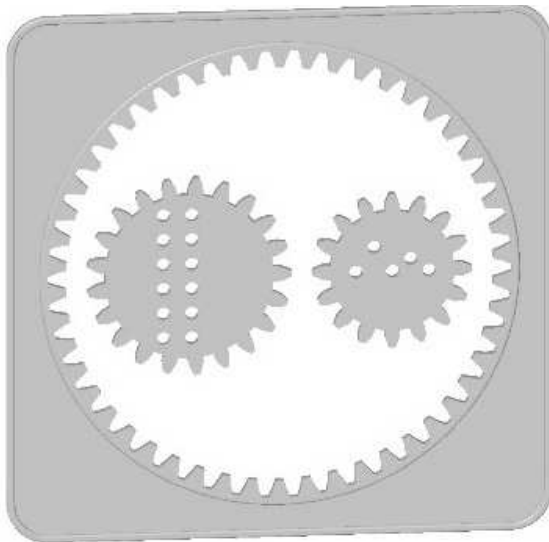

## Needed materials

In addition to a computer and a fused deposition 3D printer with the associated software, the following materials are needed for the workshop:

- FreeCAD (free and open-source CAD modeler or a similar program)
- cardboard (A4 or A3 format paper)
- pencil
- pins or adhesive tape



### ***Learning objective***

Spirograph is a great way to get students excited about engineering, specifically mathematics. Spirograph is a geometric drawing toy that produces mathematical roulette curves of the variety technically known as hypotrochoids and epitrochoids. Through the workshop, the students learn basic information about the creation of mathematical roulette curves such as cycloids, epicycloids, hypocycloids, trochoids and involutes. The students work together in small groups in which they examine and test different roulette curves designs.

It consists of two different-sized plastic rings, with gear teeth on both the inside and outside of their circumferences. They were pinned to a cardboard backing with pins, and any of several provided gearwheels, which had holes provided for a ballpoint pen to extend through them to an underlying paper writing surface. It could be spun around to make geometric shapes on the underlying paper medium.

The spirographs are manufactured with 3D printers. The students get informed about the basics about 3D printing, how the production process is working and the difference between the printing processes. They learn to operate independently with the printer and the associated software to print out the spirograph models.

After the first practical curve designs the students design their own spirographs. In the groups, they discuss how they can modify the roulette curve designs or create their own. Sketches will help the students to find their final design of the roulette curve designs and illustrate it. The students learn how to use computer-aided drawing and design system to modify the roulette curve designs or design a new one.

### ***Basics of 3D printing (introductory lesson unit)***

The teacher explains to the students how a 3D printer works, which types of printer they have, and how to handle the machine.

Some keywords the teacher should mention/explain:

- Printing process
- Layer height
- Infill / Infill Pattern
- File format
- Shell / Layer
- Design rules
- Support
- Slicer
- Raft
- Errors

## Lesson plan and activities

### 1. Teacher preparations

Every group of students should have a finished two different-sized plastic rings and bigger one to surround them. Some more different roulette curves designs should be available as reserve.



**TIP:** Print all the prepared roulette curves designs (spirographs) with the same material and infill. Print the spirographs without support material, lying flat on the building plate.

### Print settings

Raft	Yes
Support	No
Nozzle diameter	0.4 mm
Layer	0.19 mm
Infill	30%

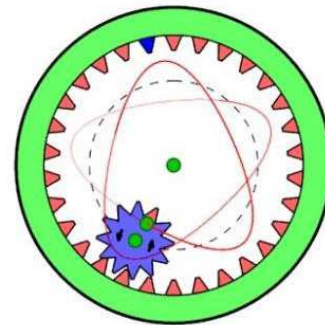

### 2. Basic principles of roulette curves designs

The teacher explains the students the mathematical basics of roulette curves designs.

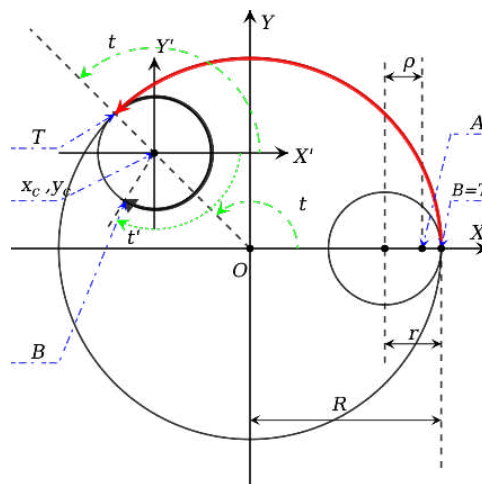

Cycloids - curve traced by a point on the rim of a circular wheel as the wheel rolls along a straight line without slipping.

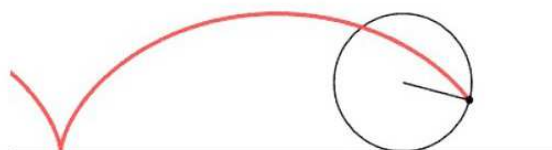

Epicycloids - plane curve produced by tracing the path of a chosen point on the circumference of a circle which rolls without slipping around a fixed circle

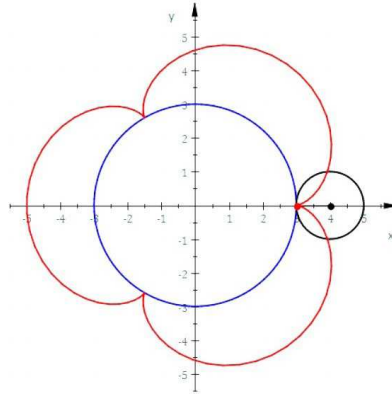

Hypocycloids - special plane curve generated by the trace of a fixed point on a small circle that rolls within a larger circle.

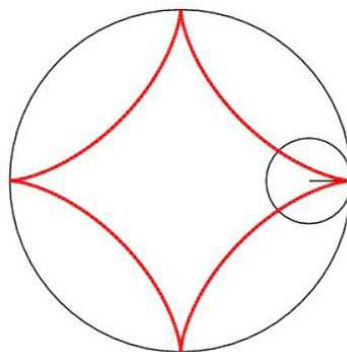

Trochoids - curve traced out by a point fixed to a circle (where the point may be on, inside, or outside the circle) as it rolls along a straight line.

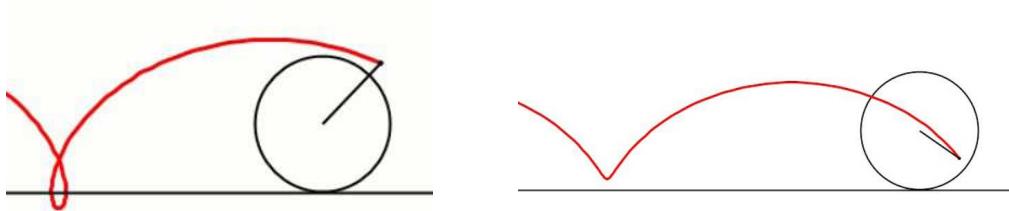

Involutes (evolvents) - a particular type of curve; it is the locus of a point on a piece of taut string as the string is either unwrapped from or wrapped around the curve.

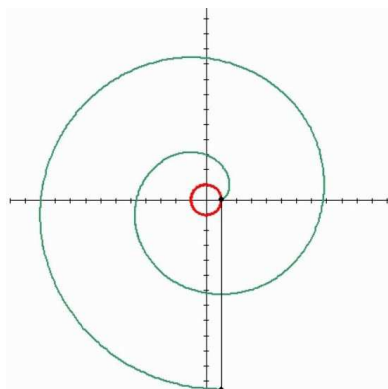

### 3. Demonstration

The teacher demonstrates several spirograph designs drawn with a spirograph set using multiple different colored pens to show how to assemble and launch one of the redesigned glider.

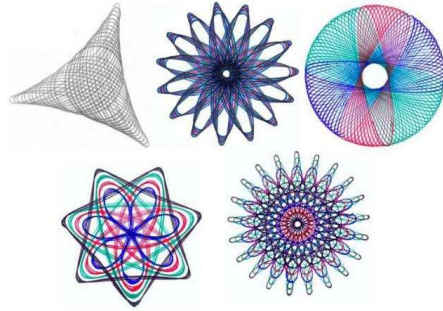

**TIP:** Use several color pens.

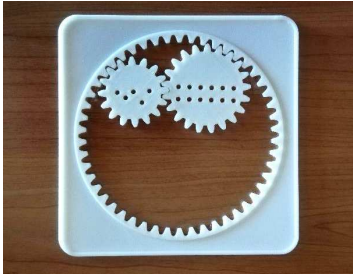

### 4. Test the spirograph designs

The student has to put in place the spirograph and start to produce different forms of designs.

### 5. Evaluate and review

Each group define the curve type which they will create. Discuss which mathematical roulette curves (cycloids, epicycloids, hypocycloids, trochoids, and involutes) can be made by this type of spirograph design. Which factors affect the way of modeling the spirograph. How can we improve, change or create our own roulette curve design.

### 6. Modification of the original printing settings and testing of the new parts

In groups, students discuss which print settings they want to change and what impact on the printed object will it have. The modified parts were printed out and tested by the students. The modified print settings are for example to increase the layer height from 0.19 mm to 0.29 mm to get a rougher surface. Know that this will decrease the printing time. The infill is another parameter that the students can modify. They can change it from the recommended 30% to 10% or 50%. Use a scale to measure the weight difference of the new parts.

**TIP:** Modify printing setting one by one to see the effect. Keep in mind that a lower infill and number of slides will reduce the weight but also reduce the stability of the spirograph.

### 7. Evaluate and review the modified spirograph

Each group calculates and evaluates the main printing parameters such as: layer thickness, printing time, infill, layer height and other printing process characteristics. Discuss which parameters have the major impact for achieving the stability of the object. Determine if the expected results occurred.

### 8. Advanced part - designing and building new spirographs

The next part of the workshop is that the students design and build their own spirograph designs.

For that, the students model their own designs by using the knowledge they got through the workshop, the discussions and tests of the different spirograph shapes. They have two possible options. The first one is to modify the existing design. The second option is to create a complete new design. The groups can decide which options they want to choose and begin planning their design.

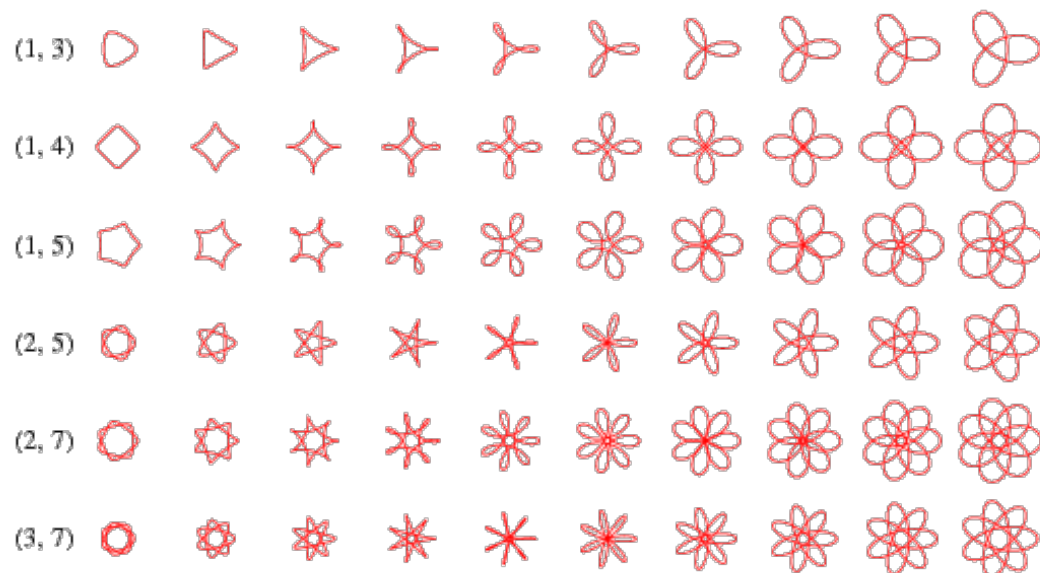

### 9. Evaluation and review of the modified design

The students print their self-made designs and test them. Determine if the changes/improvements helped as expected.

### 10. Reflections

Which spirograph designs were most effective and do they share common design traits?

What's the most important thing you learned today? Why do you think so?

Would you use 3D printing for further projects?

What do you want to learn more about, and why?

Reflect on your thinking, learning, and work today. What were you most proud of?



**3D FOR VET**

STRATEGIC PARTNERSHIP FOR THE  
DEVELOPMENT OF 3D COMPETENCES

# **Student workshop: Anemometer**

The European Commission's support for the production of this publication does not constitute an endorsement of the contents, which reflect the views only of the authors, and the Commission cannot be held responsible for any use which may be made of the information contained therein.



Erasmus+

# Contribution

## Responsible partner

- Metris Research Centre, Croatia

## Coordination

- Region of Istria, Croatia
- Regional Coordinator for European Programmes and Funds of the Region of Istria, Croatia

## Task Force / Project Partners

- Regional Coordinator for European Programmes and Funds of the Region of Istria, Croatia
- Carinthia University of Applied Sciences, Austria
- Pula Technical School, Croatia
- Metris Research Centre, Croatia
- Malopolska Voivodship, Poland
- Public Institution Panevėžys Vocational Education and Training Centre, Lithuania
- Jan Pawel II's School Miechow, Poland



# Student workshop: Anemometer

## Workshop info

Subject:	Engineering, Geography
Grades:	1 <sup>st</sup> - 2 <sup>nd</sup> class of high school
Class size:	10 to 16 students / 3 to 4 students per group
Duration:	1 day intro into 3D printing, 2 days of workshop
Skills needed:	None

## References and models

- <https://www.thingiverse.com/thing:2904388>



## Needed materials

In addition to a computer and a fused deposition 3D printer with the associated software, the following materials are needed for the workshop:

- FreeCAD (free and open-source CAD modeler or a similar program)
- available models

## Learning objective

The anemometer can be made on 3D printers. Students are introduced to the basics of 3D printing, how the production process works and the difference between the printing processes. They learn how to work independently with the printer and their anemometer model printing software.



## Basics of 3D printing (introductory lesson unit)

The teacher explains to the students how a 3D printer works, which types of printer they have, and how to handle the machine.

Some keywords the teacher should mention/explain:

- Printing process
- Layer height
- Infill / Infill Pattern
- File format
- Shell / Layer
- Design rules
- Support
- Slicer
- Raft
- Errors

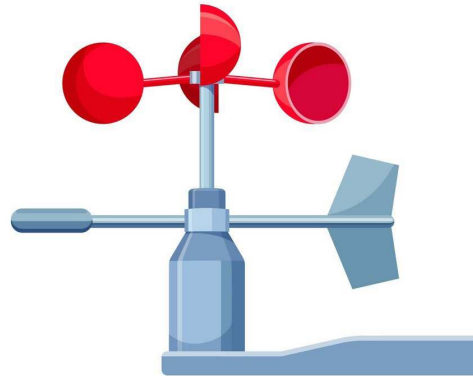

## Lesson plan and activities

### 1. Teacher preparations

Each group of students should have a basic 3D model of the basic elements of the anemometer before they begin the process of selecting the necessary parameters for 3D printing.

**TIP:** Print individual elements of the mechanism in one color (e.g. black) and the other anemometer parts in different colors and, if necessary, without supporting material, lying flat on the work platform.

### Print settings

Raft	Yes
Support	No
Nozzle diameter	0.4 mm
Layer	0.19 mm
Infill	30%

### Model examples:

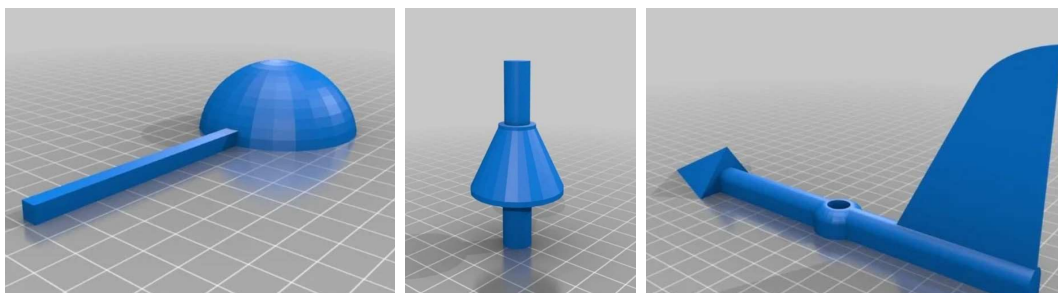

## 2. Basic structure of an anemometer

The teacher explains to the students the basic elements and function of the individual parts of the anemometer.

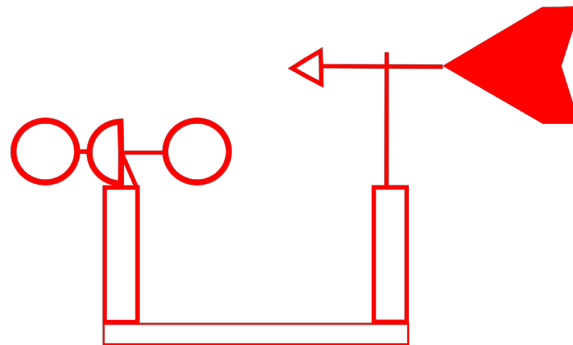

## 3. Demonstration and description

Anemometer is a measuring instrument for measuring wind strength and air flow velocity. The role of the anemometer is to measure several or all components of the wind vector. Wind is a horizontal flow of air that results from the inequality of pressure in the Earth's atmosphere. It is determined by speed and direction. In meteorology, the official wind speed unit is m / s, while the direction is determined by the English acronyms (e.g. E, NE, SW). Wind measurements are made at a height of 10 meters above the ground to avoid the negative effects of wind mixing at the ground caused by various factors.

## 4. Test of the assembly designs

Students must assemble the basic unit of the anemometer into a functional unit.

## 5. Evaluate and review

Each group presents an elaborate example of an anemometer. Discuss what all engineering topics and models can be crafted this way. What factors affect how an anemometer is modeled. How can we improve, change or create our own anemometer model design.



## 6. Modification of the original printing settings and testing of the new parts

In groups, students discuss which print settings they want to change and what impact on the printed object will it have. The modified parts were printed out and tested by the students. The modified print settings are for example to increase the layer height from 0.19 mm to 0.29 mm to get a rougher surface. Know that this will decrease the printing time. The infill is another parameter that the students can modify. They can change it from the recommended 30% to 20% or 40%. Use a scale to measure the weight difference of the new parts.

**TIP:** Modify printing setting one by one to see the effect. Keep in mind that a lower infill and number of slides will reduce the weight but also reduce the stability.

## 7. Evaluate and review the modified parts and whole anemometer

Each group calculates and evaluates the main printing parameters such as: layer thickness, printing time, infill, layer height and other printing process characteristics. Discuss which parameters have the major impact for achieving the stability of the object. Determine if the expected results occurred.

## 8. Advanced part - designing and building new modified parts of anemometer or the whole unit

The next part of the workshop is that the students design and build their own designs of the anemometer and different anemometer unit parts.

For that, the students model their own designs by using the knowledge they got through the workshop, the discussions and test of the anemometer parts and shapes. They have two possible options. The first one is to modify the existing design. The second option is to create a complete new design. The groups can decide which options they want to choose and begin planning their design.

### Different examples:

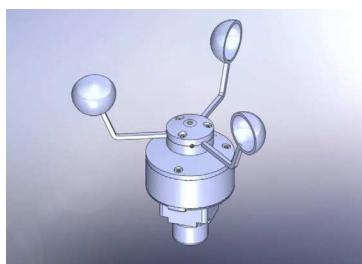
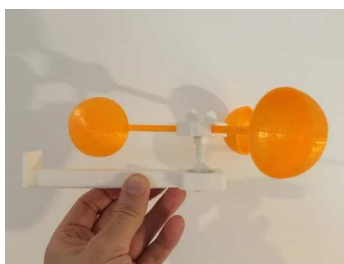

### 9. Evaluation and review of the modified design

The students print their self-made designs and test them. Determine if the changes/improvements helped as expected.

### 10. Reflections

What anemometer designs were the most efficient and what common design links do they have?

What's the most important thing you learned today? Why do you think so?

Would you use 3D printing for further projects?

What do you want to learn more about, and why?

Reflect on your thinking, learning, and work today. What were you most proud of?



**3D FOR VET**

STRATEGIC PARTNERSHIP FOR THE  
DEVELOPMENT OF 3D COMPETENCES

# **Student workshop: French key (Monkey wrench)**

The European Commission's support for the production of this publication does not constitute an endorsement of the contents, which reflect the views only of the authors, and the Commission cannot be held responsible for any use which may be made of the information contained therein.



Erasmus+

# Contribution

## Responsible partner

- Metris Research Centre, Croatia

## Coordination

- Region of Istria, Croatia
- Regional Coordinator for European Programmes and Funds of the Region of Istria, Croatia

## Task Force / Project Partners

- Regional Coordinator for European Programmes and Funds of the Region of Istria, Croatia
- Carinthia University of Applied Sciences, Austria
- Pula Technical School, Croatia
- Metris Research Centre, Croatia
- Malopolska Voivodship, Poland
- Public Institution Panevėžys Vocational Education and Training Centre, Lithuania
- Jan Pawel II's School Miechow, Poland



# Student workshop: French key (Monkey wrench)

## *Workshop info*

<b>Subject:</b>	Engineering, Quality Control
<b>Grades:</b>	1 <sup>st</sup> - 2 <sup>nd</sup> class of high school
<b>Class size:</b>	10 to 16 students / 1 to 2 students per group
<b>Duration:</b>	1 day intro into 3D printing, 1 day of workshop
<b>Skills needed:</b>	None



## *References and models*

- <https://www.thingiverse.com/thing:139268>

## *Needed materials*

In addition to a computer and a fused deposition 3D printer with the associated software, the following materials are needed for the workshop:

- FreeCAD (free and open-source CAD modeler or a similar program)
- available models

## *Learning objective*

This wrench can be created on 3D printers. Students are introduced to the basics of 3D printing, how the production process works and the difference between the printing processes. They learn to work independently with the printer and associated software for printing the French key i.e. the monkey wrench.

## Basics of 3D printing (introductory lesson unit)

The teacher explains to the students how a 3D printer works, which types of printer they have, and how to handle the machine.

Some keywords the teacher should mention/explain:

- Printing process
- Layer height
- Infill / Infill Pattern
- File format
- Shell / Layer
- Design rules
- Support
- Slicer
- Raft
- Errors



## Lesson plan and activities

### 1. Teacher preparations

Each group of students should have a basic 3D model of the monkey wrench before they begin the process of selecting the necessary parameters for 3D printing.

**TIP:** Print this wrench without supporting material, lying flat on the work platform

### Print settings

Raft	Yes
Support	No
Nozzle diameter	0.4 mm
Layer	0.29 mm
Infill	30%

### Model examples:

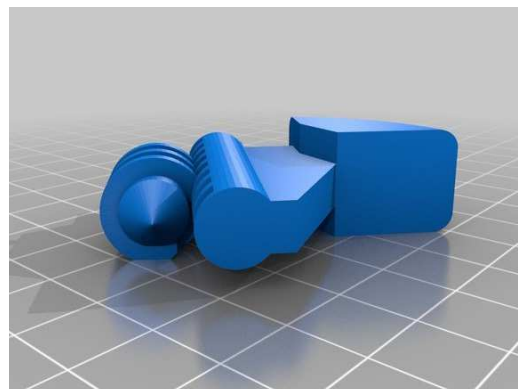
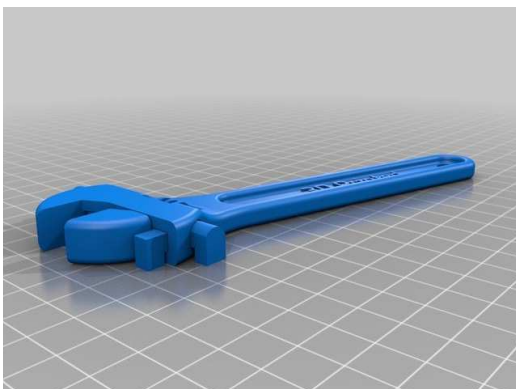



## 2. Basic structure of French key

The teacher explains to the students the basic elements of the French key. It is a tool with parts that can be moved to tighten or unfasten any size of nut and bolts.

## 3. Demonstration and description

A French key is an adjustable wrench with jaws oriented up to 90 degrees to the handle. In theory it is used to turn nuts and bolts, in practice it rounds over pipes, nuts and bolts. It is similar to a pipe wrench at first glance.

## 4. Test of the design of the French key

Students must use this tool to ensure the functionality and stability of the printed object.

## 5. Evaluate and review

Each group presents an elaborate example of the wrench. Discuss what all engineering topics and models can be crafted this way. What factors affect how the French key is modeled? How can we improve, change or create our own French key model design?

## 6. Modification of the original printing settings and testing of the new parts

In groups, students discuss which print settings they want to change and what impact on the printed object will it have. The modified parts are printed out and tested by the students. The modified print settings are for example to decrease the layer height from 0.29 mm to 0.19 mm to get finer surface. Know that this will increase the printing time. The infill is another parameter that the students can modify. They can change it from the recommended 30% to 20% or 10%. Use a scale to measure the weight difference of the new parts.

**TIP:** Modify printing setting one by one to see the effect. Keep in mind that a lower infill and number of slides will decrease the weight but also the stability.

## 7. Evaluate and review the modified parts and whole French key

Each group calculates and evaluates the main printing parameters such as: layer thickness, printing time, infill, layer height and other printing process characteristics. Discuss which parameters have the major impact for achieving the stability of the object. Determine if the expected results occurred.

## 8. Advanced part - design and build new modified parts of the French key

The next part of the workshop is that the students design and build their own designs of the French key.

For that, the students model their own designs by using the knowledge they got through the workshop, the discussions and test of the French key shapes. They have two possible options. The first one is to modify the existing design. The second option is to create a complete new design. The groups can decide which options they want to choose and begin planning their design.

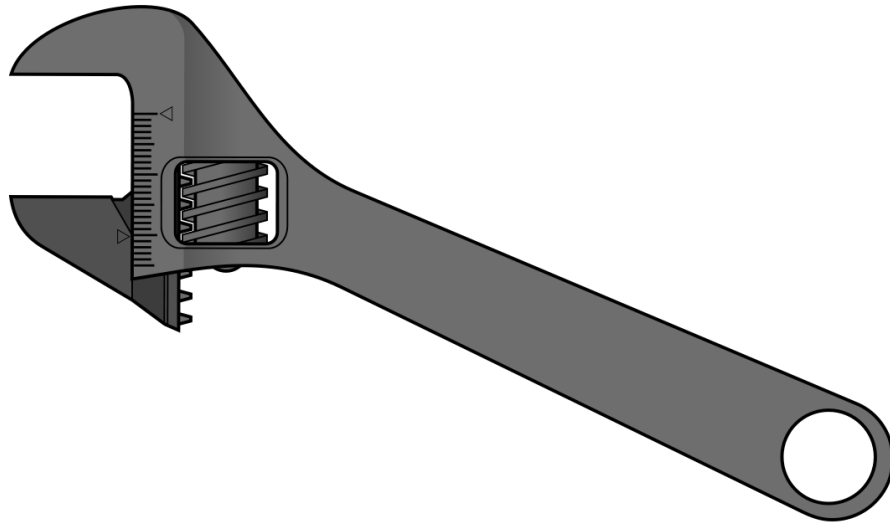

## 9. Evaluation and review of the modified design

The students print their self-made designs and test them. Determine if the changes/improvements helped as expected.

## 10. Reflections

What designs of the French key were the most efficient and what common design links do they have?

What's the most important thing you learned today? Why do you think so?

Would you use 3D printing for further projects?

What do you want to learn more about, and why?

Reflect on your thinking, learning, and work today. What were you most proud of?



# 3D FOR VET

STRATEGIC PARTNERSHIP FOR THE  
DEVELOPMENT OF 3D COMPETENCES

# Student workshop: Scorpion

The European Commission's support for the production of this publication does not constitute an endorsement of the contents, which reflect the views only of the authors, and the Commission cannot be held responsible for any use which may be made of the information contained therein.



Erasmus+

# Contribution

## Responsible partner

- Metris Research Centre, Croatia

## Coordination

- Region of Istria, Croatia
- Regional Coordinator for European Programmes and Funds of the Region of Istria, Croatia

## Task Force / Project Partners

- Regional Coordinator for European Programmes and Funds of the Region of Istria, Croatia
- Carinthia University of Applied Sciences, Austria
- Pula Technical School, Croatia
- Metris Research Centre, Croatia
- Malopolska Voivodship, Poland
- Public Institution Panevėžys Vocational Education and Training Centre, Lithuania
- Jan Pawel II's School Miechow, Poland



# Student workshop: Scorpion

## *Workshop info*

<b>Subject:</b>	Biology
<b>Grades:</b>	1 <sup>st</sup> - 2 <sup>nd</sup> class of high school
<b>Class size:</b>	10 to 16 students / 2 to 3 students per group
<b>Duration:</b>	1 day intro into 3D printing, 1 day of workshop
<b>Skills needed:</b>	None

## *References and models*

- <https://www.thingiverse.com/thing:182363>



## *Needed materials*

In addition to a computer and a fused deposition 3D printer with the associated software, the following materials are needed for the workshop:

- FreeCAD (free and open-source CAD modeler or a similar program)
- available models

## Learning objective

Scorpion is an animal that during the day most species spend time buried underground and rocks in "tunnels" they have dug themselves, and there are species that rest on the surface hanging from rocks or branches. It is a great example of how to get students interested in biology, that is, to learn the basics of scorpion structure. Students work together in small groups where they make basic parts of scorpions.

Scorpion can be made on 3D printers. Students are introduced to the basics of 3D printing, how the production process works and the difference between the printing processes. They learn to work independently with the printer and the associated scorpion model printing software.

## Basics of 3D printing (introductory lesson unit)

The teacher explains to the students how a 3D printer works, which types of printer they have, and how to handle the machine.

Some keywords the teacher should mention/explain:

- Printing process
- Layer height
- Infill / Infill Pattern
- File format
- Shell / Layer
- Design rules
- Support
- Slicer
- Raft
- Errors

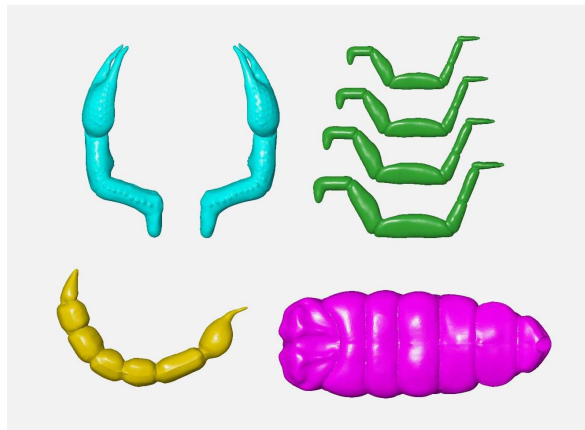

## Lesson plan and activities

### 1. Teacher preparations

Each group of students should have a basic 3D model of the basic elements of the scorpion model before they begin the process of selecting the necessary parameters for 3D printing.

**TIP:** Print individual elements/body parts of the scorpion with material in different colors and, if necessary, without supporting material, lying flat on the work platform.

### Print settings

Raft	Yes
Support	No
Nozzle diameter	0.4 mm
Layer	0.19 mm
Infill	20%

### Model examples:

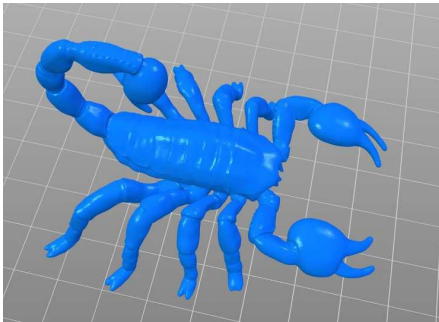

### 2. Basic structure of a scorpion

The teacher explains to the students the basic elements and function of the individual parts of the animal.

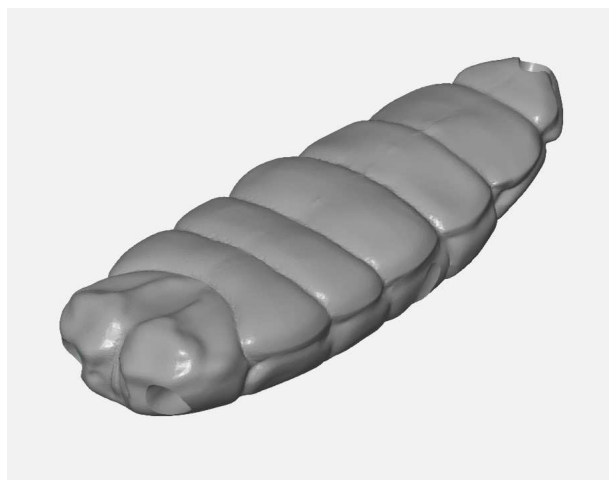
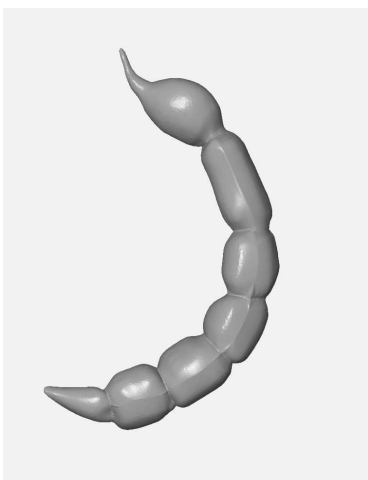
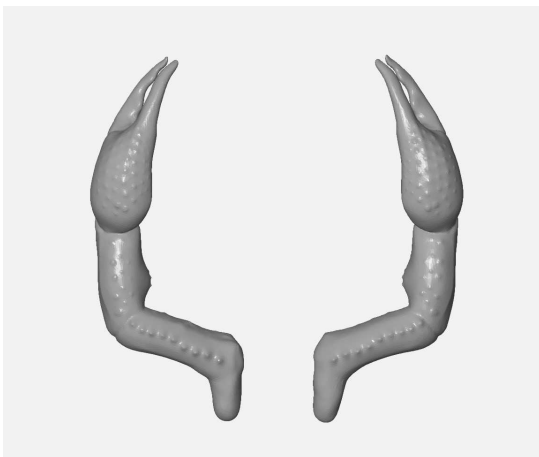

### 3. Demonstration and description

A scorpion is an order in the class of spiders that belong to arthropods.

Typical of scorpions is that they are covered in solid chitin armor. They have two scissor-like pliers near their head, with which they can catch prey. Like all spiders, scorpions have 4 pairs of legs. The back is like a tail, ending with a single venomous sting, where it has poisonous glands.

Scorpions belong to the class of spiders, along with spiders and mites. Scorpions are arthropods, they are invertebrates and are named after articulated legs. They range in size from 13 mm to 25 cm.

### 4. Test of the assembly designs

Students must assemble the basic units of the scorpion from an example and parts already available to them.



### 5. Evaluate and review

Each group presents an elaborate example of a scorpion. Discuss what all biology topics and models can be crafted this way. What factors affect how a scorpion is modeled. How can we improve, change or create our own scorpion model design.

### 6. Modification of the original printing settings and testing of the new parts

In groups, students discuss which print settings they want to change and what impact on the printed object will it have. The modified parts were printed out and tested by the students. The modified print settings are for example to decrease the layer height from 0.19 mm to 0.14 mm to get a smoother surface. Know that this will increase the printing time. The infill is another parameter that the students can modify. They can change it from the recommended 20% to 10% or 50%. Use a scale to measure the weight difference of the new parts.

**TIP:** Modify printing setting one by one to see the effect. Keep in mind that a lower infill and number of slides will reduce the weight but also reduce the stability.



### 7. Evaluate and review the modified parts and whole animal

Each group calculates and evaluates the main printing parameters such as: layer thickness, printing time, infill, layer height and other printing process characteristics. Discuss which parameters have the major impact for achieving the stability of the object. Determine if the expected results occurred.

### 8. Advanced part - designing and building new modified parts or the whole animal

The next part of the workshop is that the students design and build their own designs of the animal and different body parts.

For that, the students model their own designs by using the knowledge they got through the workshop, the discussions and test of the animal parts and shapes. They have two possible options. The first one is to modify the existing design. The second option is to create a complete new design. The groups can decide which options they want to choose and begin planning their design.

### 9. Evaluation and review of the modified design

The students print their self-made designs and test them. Determine if the changes/improvements helped as expected.

### 10. Reflections

What animal designs were the most efficient and what common design links do they have?

What's the most important thing you learned today? Why do you think so?

Would you use 3D printing for further projects?

What do you want to learn more about, and why?

Reflect on your thinking, learning, and work today. What were you most proud of?



## 3D FOR VET

STRATEGIC PARTNERSHIP FOR THE  
DEVELOPMENT OF 3D COMPETENCES

# Student workshop: Propeller toy

The European Commission's support for the production of this publication does not constitute an endorsement of the contents, which reflect the views only of the authors, and the Commission cannot be held responsible for any use which may be made of the information contained therein.



Erasmus+

# Contribution

## Responsible partner

- Metris Research Centre, Croatia

## Coordination

- Region of Istria, Croatia
- Regional Coordinator for European Programmes and Funds of the Region of Istria, Croatia

## Task Force / Project Partners

- Regional Coordinator for European Programmes and Funds of the Region of Istria, Croatia
- Carinthia University of Applied Sciences, Austria
- Pula Technical School, Croatia
- Metris Research Centre, Croatia
- Malopolska Voivodship, Poland
- Public Institution Panevėžys Vocational Education and Training Centre, Lithuania
- Jan Pawel II's School Miechow, Poland



# Student workshop: Propeller toy

## Workshop info

Subject:	Engineering
Grades:	1 <sup>th</sup> -4 <sup>th</sup> class of high school
Class size:	10 to 16 students / 2 to 3 students per group
Duration:	1 day intro into 3D printing, 1 day of workshop
Skills needed:	None

## References and models

- <https://pinshape.com/items/22387-3d-printed-propeller-toy>



## Needed materials

In addition to a computer and a fused deposition 3D printer with the associated software, the following materials are needed for the workshop:

- FreeCAD (free and open-source CAD modeler or a similar program)
- available models
- 2x Socket Head Screw M3x0.5, 25 mm long (18 mm threaded)
- glue

## *Learning objective*

A propeller is a device with a rotating hub and blades that are tilted to form a helical coil that, when rotated, performs an action similar to an Archimedean screw. It converts rotational power into linear thrust by acting on a working fluid such as water or air. The rotational motion of the blades is converted into a force by creating a pressure difference between the two surfaces. The working fluid mass accelerates in one direction and the object (vessel, aircraft) moves in the opposite direction. Propeller dynamics, such as those on the wings of an aircraft, can be modeled on Bernoulli's principle and Newton's third law. Most marine propellers are helical screws with spiral blades that rotate around the horizontal axis or the propeller shaft. Also, a gearbox with a propeller is used in processes where continuous mixing of the media is required (i.e. dairy industry, creamery, etc.).

## *Basics of 3D printing (introductory lesson unit)*

The teacher explains to the students how a 3D printer works, which types of printer they have, and how to handle the machine.

Some keywords the teacher should mention/explain:

- Printing process
- Layer height
- Infill / Infill Pattern
- File format
- Shell / Layer
- Design rules
- Support
- Slicer
- Raft
- Errors

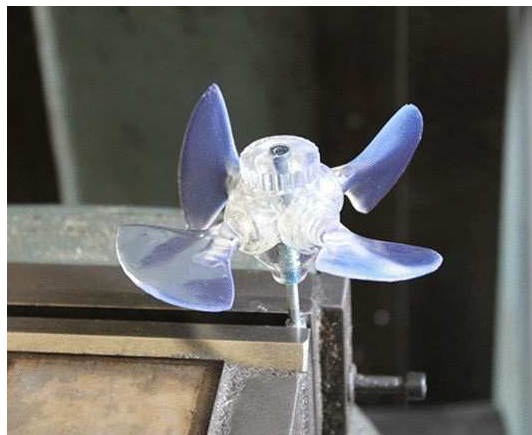

## *Lesson plan and activities*

### *1. Teacher preparations*

Each group of students should have the M3 hexagon screws secured before finally assembling of the propeller toy.

**TIP:** Print all the prepared designs of the propeller toy with the same material and infill. Print the propeller toy without support material, lying flat on the building plate.

## Print settings

Raft	Yes
Support	No
Nozzle diameter	0.4 mm
Layer	0.19 mm
Infill	20%

## 2. Basic principles of the propeller toy

The teacher explains to the students the basic elements as well as the functioning of the propeller toy.

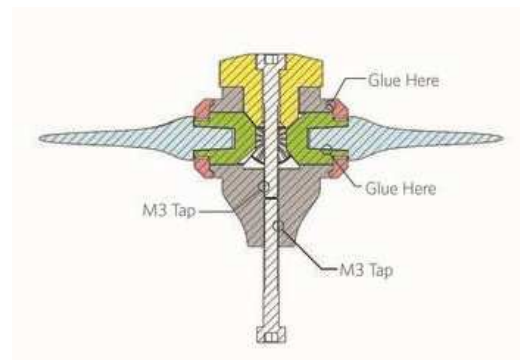
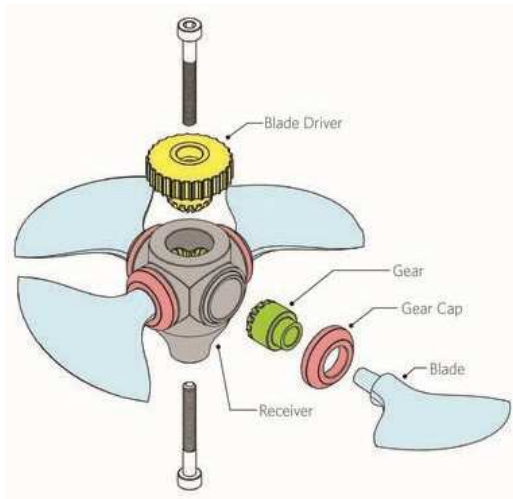

## 3. Demonstration

The teacher demonstrates several propeller toys.



#### 4. Test the propeller toy

Students must assemble the gear unit with the propellers.

The gear (red) must be inserted into the gear housing (purple) before the gear cover (yellow) is inserted. This ensures that the gear is positioned correctly in the gearbox housing. The propellers are glued to the gears after the gear has already been positioned in the gear housing. The blade driver (blue) and propeller gear (red & green) are tapped in center of the housing. The tightening of the bolts M3 against each other secures them in position.

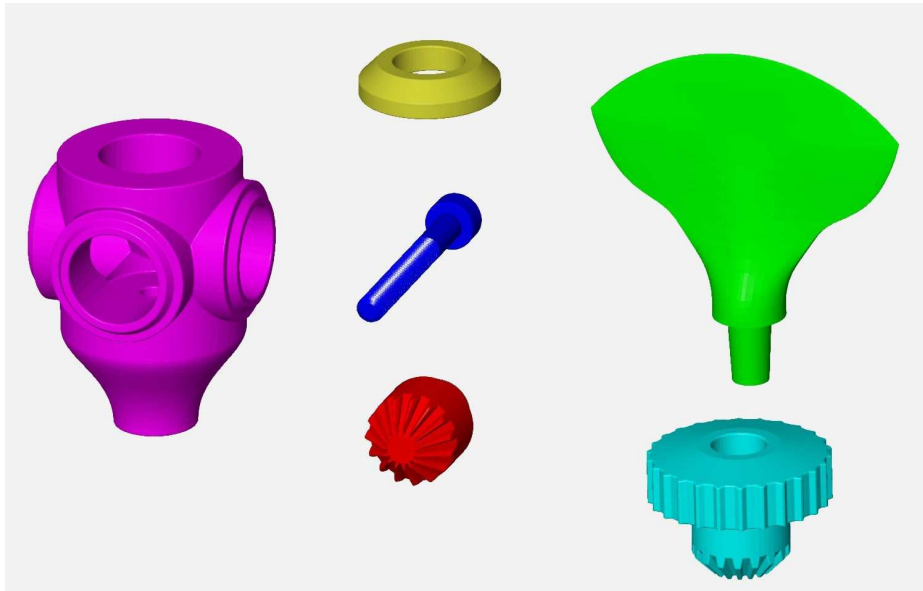

#### 5. Evaluate and review

Each group defines the propeller toy type which they will create. Discuss which objects can be made by this type of design. Which factors affect the way of modeling the propeller toy. How can we improve, change or create an own design of the propeller toy.

#### 6. Modification of the original printing settings and testing of the new parts

In groups, students discuss which print settings they want to change and what impact on the printed object will it have. The modified parts were printed out and tested by the students. The modified print settings are for example to increase the layer height from 0.19 mm to 0.29 mm to get a rougher surface. Know that this will decrease the printing time. The infill is another parameter that the students can modify. They can change it from the recommended 20% to 10% or 30%. Use a scale to measure the weight difference of the new parts.

**TIP:** Modify printing setting one by one to see the effect. Keep in mind that a lower infill and number of slides will reduce the weight but also reduce the stability of the propeller toy.

### 7. Evaluate and review the modified propeller toy

Each group calculates and evaluates the main printing parameters such as: layer thickness, printing time, infill, layer height and other printing process characteristics. Discuss which parameters have the major impact for achieving the stability of the object. Determine if the expected results occurred.

### 8. Advanced part - designing and building new propeller toy

The next part of the workshop is that the students design and build their own propeller toy designs.

For that, the students model their own designs by using the knowledge they got through the workshop, the discussions and tests of the different propeller toy shapes. They have two possible options. The first one is to modify the existing design. The second option is to create a complete new design. The groups can decide which options they want to choose and begin planning their design.

### 9. Evaluation and review of the modified design

The students print their self-made designs and test them. Determine if the changes/improvements helped as expected.

### 10. Reflections

Which propeller toy designs were most effective and do they share common design traits?

What's the most important thing you learned today? Why do you think so?

Would you use 3D printing for further projects?

What do you want to learn more about, and why?

Reflect on your thinking, learning, and work today. What were you most proud of?





**3D FOR VET**

STRATEGIC PARTNERSHIP FOR THE  
DEVELOPMENT OF 3D COMPETENCES

# **Student workshop: 3D printer test**

The European Commission's support for the production of this publication does not constitute an endorsement of the contents, which reflect the views only of the authors, and the Commission cannot be held responsible for any use which may be made of the information contained therein.



Erasmus+

# Contribution

## Responsible partner

- Metris Research Centre, Croatia

## Coordination

- Region of Istria, Croatia
- Regional Coordinator for European Programmes and Funds of the Region of Istria, Croatia

## Task Force / Project Partners

- Regional Coordinator for European Programmes and Funds of the Region of Istria, Croatia
- Carinthia University of Applied Sciences, Austria
- Pula Technical School, Croatia
- Metris Research Centre, Croatia
- Malopolska Voivodship, Poland
- Public Institution Panevėžys Vocational Education and Training Centre, Lithuania
- Jan Pawel II's School Miechow, Poland



# Student workshop: 3D printer test

## Workshop info

<b>Subject:</b>	Engineering, Quality Control
<b>Grades:</b>	1 <sup>st</sup> - 2 <sup>nd</sup> class of high school
<b>Class size:</b>	10 to 16 students / 1 to 2 students per group
<b>Duration:</b>	1 day intro into 3D printing, 1 day of workshop
<b>Skills needed:</b>	None



## References and models

- <https://www.thingiverse.com/thing:2656594>

## Needed materials

In addition to a computer and a fused deposition 3D printer with the associated software, the following materials are needed for the workshop:

- FreeCAD (free and open-source CAD modeler or a similar program)
- available models

## Learning objective

This 3D printer test can be created on 3D printers. Students are introduced to the basics of 3D printing, how the production process works and the difference between the printing processes. They learn to work independently with the printer and associated software for printing the 3D printing test.

## Basics of 3D printing (introductory lesson unit)

The teacher explains to the students how a 3D printer works, which types of printer they have, and how to handle the machine.

Some keywords the teacher should mention/explain:

- Printing process
- Layer height
- Infill / Infill Pattern
- File format
- Shell / Layer
- Design rules
- Support
- Slicer
- Raft
- Errors

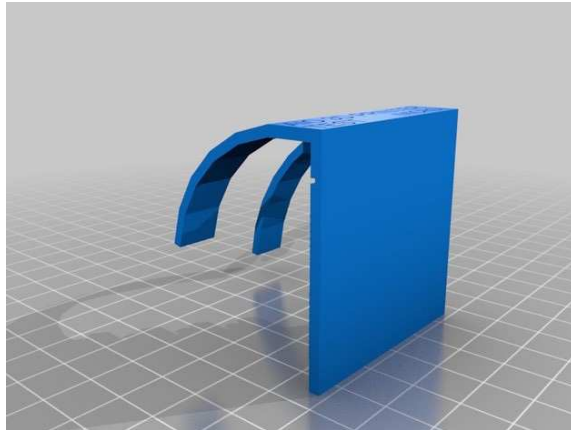

## Lesson plan and activities

### 1. Teacher preparations

Each group of students should have a basic 3D model of the test parts before they begin the process of selecting the necessary parameters for 3D printing.

**TIP:** Print the 3D printer test without supporting material, lying flat on the work platform.

### Print settings

Raft	Yes
Support	No
Nozzle diameter	0.4 mm
Layer	0.14 mm
Infill	100%

### Model examples:

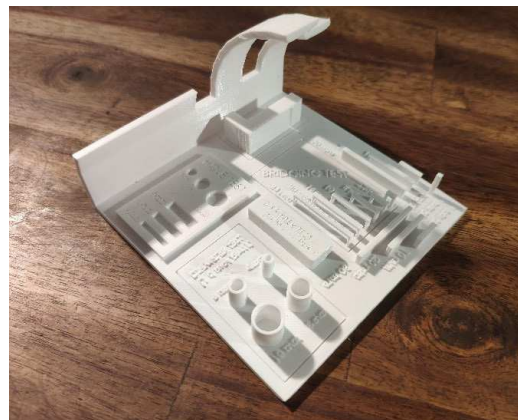

## 2. Basic structure of the 3D printer test

The teacher explains to the students the basic functions of the 3D printer test. A comprehensive 3D printer test is a way to check the basic geometry characteristics of a print job. This test contains: overhang test, bridging test, stringing test, sharp-corner test, tolerance test, and scale test (diameter test).

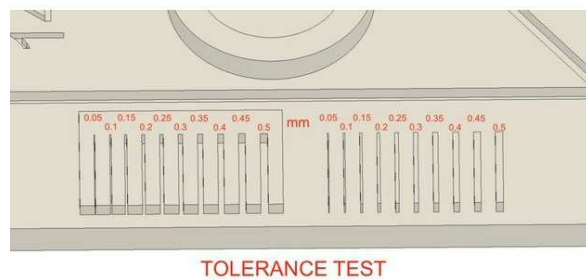
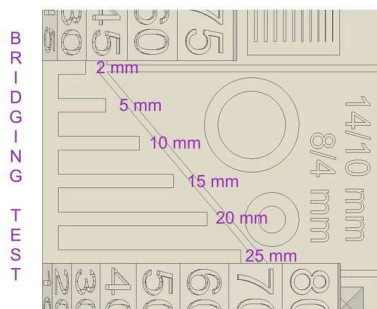
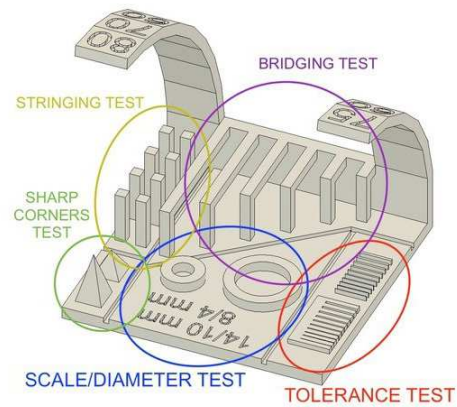
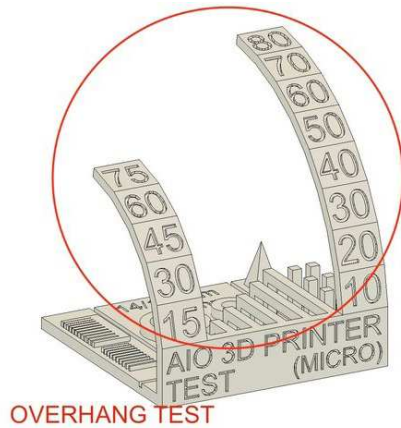

## 3. Demonstration and description

The wide availability of 3D printing technology requires to assure the geometric accuracy for certain 3D printers on the market, in order to determine which 3D printers can provide dimensional stability for printed objects.

#### 4. Test the design of the 3D printer test

Students must present the produced 3D printing test.



#### 5. Evaluate and review

Each group presents an elaborated example of the 3D printer test. Discuss what all engineering topics and models can be crafted this way. What factors affect how the 3D printer test is modeled. How can we improve, change or create our own 3D printer test design.

#### 6. Modification of the original printing settings and testing of the new parts

In groups, students discuss which print settings they want to change and what impact on the printed object will it have. The modified parts are printed out and tested by the students. The modified print settings are for example to increase the layer height from 0.14 mm to 0.29 mm to get a rougher surface. Know that this will decrease the printing time. The infill is another parameter that the students can modify. They can change it from the recommended 100% to 50% or 30%. Use a scale to measure the weight difference of the new parts.

**TIP:** Modify printing setting one by one to see the effect. Keep in mind that a lower infill and number of slides will reduce the weight but also reduce the stability of the 3D printer test.

#### 7. Evaluation and review of the modified 3D printer test

Each group calculates and evaluates the main printing parameters such as: layer thickness, printing time, infill, layer height and other printing process characteristics. Discuss which parameters have the major impact for achieving the stability of the object. Determine if the expected results occurred.

## 8. Advanced part - designing and building new modified design of 3D printer test

The next part of the workshop is that the students design and build their own designs of the 3D printer test.

For that, the students model their own designs by using the knowledge they got through the workshop, the discussions and test of the 3D printer test shapes. They have two possible options. The first one is to modify the existing design. The second option is to create a complete new design. The groups can decide which options they want to choose and begin planning their design.

## 9. Evaluation and review of the modified design

The students print their self-made designs and test them. Determine if the changes/improvements helped as expected.

## 10. Reflections

What designs of the 3D printer test were the most efficient and what common design links do they have?

What's the most important thing you learned today? Why do you think so?

Would you use 3D printing for further projects?

What do you want to learn more about, and why?

Reflect on your thinking, learning, and work today. What were you most proud of?



## 3D FOR VET

STRATEGIC PARTNERSHIP FOR THE  
DEVELOPMENT OF 3D COMPETENCES

# Student workshop: Maltese cross / Geneva drive

The European Commission's support for the production of this publication does not constitute an endorsement of the contents, which reflect the views only of the authors, and the Commission cannot be held responsible for any use which may be made of the information contained therein.



Erasmus+



# Contribution

## Responsible partner

- Metris Research Centre, Croatia

## Coordination

- Region of Istria, Croatia
- Regional Coordinator for European Programmes and Funds of the Region of Istria, Croatia

## Task Force / Project Partners

- Regional Coordinator for European Programmes and Funds of the Region of Istria, Croatia
- Carinthia University of Applied Sciences, Austria
- Pula Technical School, Croatia
- Metris Research Centre, Croatia
- Malopolska Voivodship, Poland
- Public Institution Panevėžys Vocational Education and Training Centre, Lithuania
- Jan Pawel II's School Miechow, Poland



# Student workshop: Maltese cross / Geneva drive

## *Workshop info*

<b>Subject:</b>	Physics (Kinematics)
<b>Grades:</b>	1 <sup>st</sup> - 2 <sup>nd</sup> class of high school
<b>Class size:</b>	10 to 16 students / 1 to 2 students per group
<b>Duration:</b>	1 day intro into 3D printing, 1 day of workshop
<b>Skills needed:</b>	None

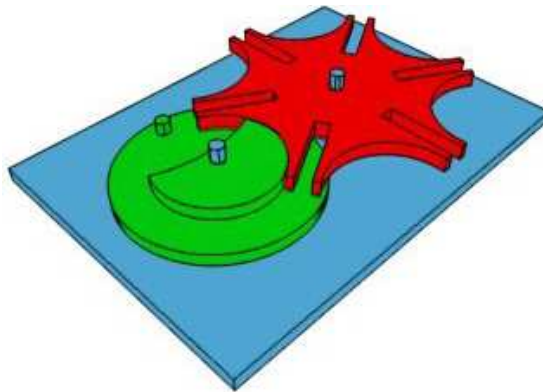

## *References and models*

- <https://www.thingiverse.com/thing:2944616>

## *Needed materials*

In addition to a computer and a fused deposition 3D printer with the associated software, the following materials are needed for the workshop:

- FreeCAD (free and open-source CAD modeler or a similar program)
- available models

## *Learning objective*

This mechanism can be created on 3D printers. Students are introduced to the basics of 3D printing, how the production process works and the difference between the printing processes. They learn to work independently with the printer and associated software for printing the Geneva drive (mechanism model), i.e. the Maltese cross.

## Basics of 3D printing (introductory lesson unit)

The teacher explains to the students how a 3D printer works, which types of printer they have, and how to handle the machine.

Some keywords the teacher should mention/explain:

- Printing process
- Infill / Infill Pattern
- Shell / Layer
- Support
- Raft
- Layer height
- File format
- Design rules
- Slicer
- Errors



## Lesson plan and activities

### 1. Teacher preparations

Each group of students should have a basic 3D model of the mechanism parts before they begin the process of selecting the necessary parameters for 3D printing.

**TIP:** Print individual elements of the mechanism with material in different colors and, if necessary, without supporting material, lying flat on the work platform

### Print settings

Raft	Yes
Support	No
Nozzle diameter	0.4 mm
Layer	0.19 mm
Infill	20%

### Model examples:



## 2. Basic structure of the Maltese cross

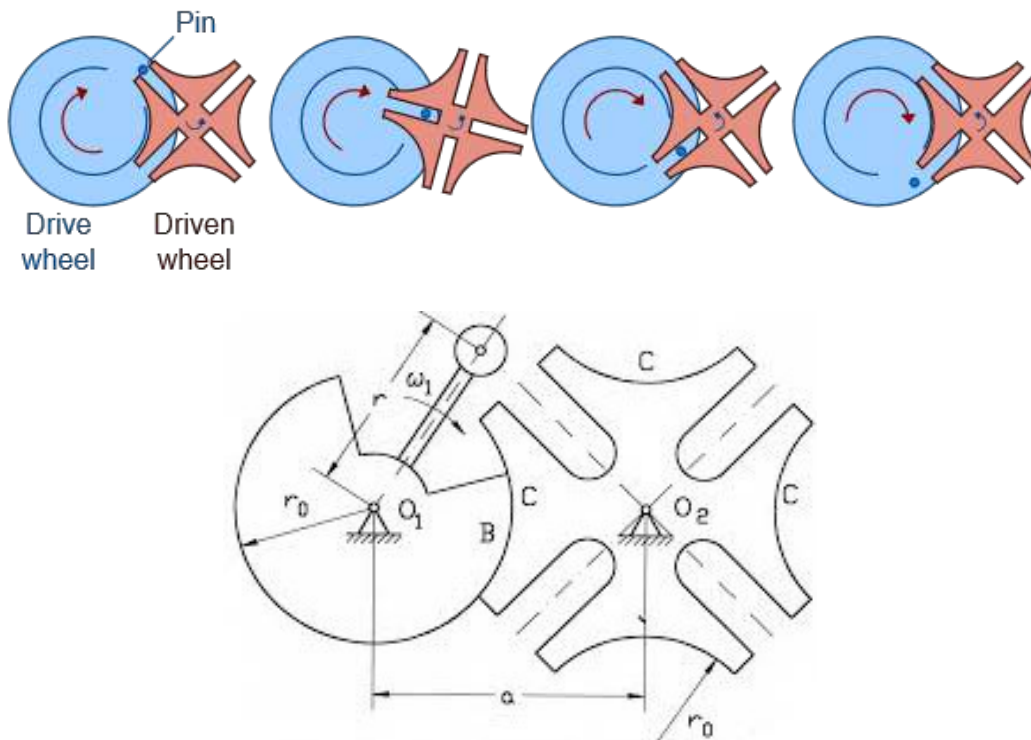

The teacher explains to the students the basic elements and function of the individual parts of the Maltese cross.

## 3. Demonstration and description

The mechanism of the Maltese cross (Geneva mechanism) consists of a propulsion and propulsion member. The drive member is made in the form of a crank (axle knee) with a roller, and the drive member is a slit plate (reminiscent of the Maltese order, by which the mechanism was named).

It is a special mechanism, a type of mechanical switch, that allows the circular motion of the drive part to be transformed into stepped (intermittent) motion of the driven part. The Maltese crosses have numerous designs that differ from each other in the form of the drive and driven parts. It is mainly the drive part of the pin lever and sometimes has a moon-shaped circular projection. The pin enters the grooves, and the moonlight protrudes along the curved recesses on the chased part. The number of grooves on the driven part depends on the required number of steps in one motion cycle. In most cases, the driven part has outer transverse grooves that are rounded at the bottom. The angular velocity of the driven part changes from 0 to maximum, depending on the current position of the pin in the slot. The highest angular velocity is when the pin touches the bottom of the slot of the driven member, and 0 is when the pin exits the slot. The driven part may also have different groove designs, for example cycloid grooves. The grooves may be at the outer circumference or inside the bore in the driven portion.

#### 4. Test of the assembly design of the mechanism

Students must assemble the mechanism parts into a functional unit.



#### 5. Evaluate and review

Each group presents an elaborate example of the mechanism. Discuss what all engineering topics and models can be crafted this way. What factors affect how the Maltese cross is modeled. How can we improve, change or create our own Maltese cross model design.



#### 6. Modification of the original printing settings and testing of the new parts

In groups, students discuss which print settings they want to change and what impact on the printed object will it have. The modified parts were printed out and tested by the students. The modified print settings are for example to increase the layer height from 0.14 mm to 0.19 mm to get a rougher surface. Know that this will decrease the printing time. The infill is another parameter that the students can modify. They can change it from the recommended 20% to 30% or 40%. Use a scale to measure the weight difference of the new parts.

**TIP:** Modify printing setting one by one to see the effect. Keep in mind that a lower infill and number of slides will reduce the weight but also reduce the stability.

### 7. Evaluate and review the modified parts and the whole Maltese cross

Each group calculates and evaluates the main printing parameters such as: layer thickness, printing time, infill, layer height and others printing process characteristics. Discuss which parameters have the major impact for achieving the stability of the object. Determine if the expected results occurred.

### 8. Advanced part - designing and building new modified parts of the mechanism or the whole unit

The next part of the workshop is that the students design and build their own designs of the mechanism and different mechanism unit parts.

For that, the students model their own designs by using the knowledge they got through the workshop, the discussions and test of the mechanism parts and shapes. They have two possible options. The first one is to modify the existing design. The second option is to create a complete new design. The groups can decide which options they want to choose and begin planning their design.

### 9. Evaluation and review of the modified design

The students print their self-made designs and test them. Determine if the changes/improvements helped as expected.

### 10. Reflections

What designs of the Maltese cross were the most efficient and what common design links do they have?

What's the most important thing you learned today? Why do you think so?

Would you use 3D printing for further projects?

What do you want to learn more about, and why?

Reflect on your thinking, learning, and work today. What were you most proud of?



**3D FOR VET**

STRATEGIC PARTNERSHIP FOR THE  
DEVELOPMENT OF 3D COMPETENCES

# **Student workshop: Ionic bond**

The European Commission's support for the production of this publication does not constitute an endorsement of the contents, which reflect the views only of the authors, and the Commission cannot be held responsible for any use which may be made of the information contained therein.



Erasmus+

# Contribution

## Responsible partner

- Metris Research Centre, Croatia

## Coordination

- Region of Istria, Croatia
- Regional Coordinator for European Programmes and Funds of the Region of Istria, Croatia

## Task Force / Project Partners

- Regional Coordinator for European Programmes and Funds of the Region of Istria, Croatia
- Carinthia University of Applied Sciences, Austria
- Pula Technical School, Croatia
- Metris Research Centre, Croatia
- Malopolska Voivodship, Poland
- Public Institution Panevėžys Vocational Education and Training Centre, Lithuania
- Jan Pawel II's School Miechow, Poland





# Student workshop: Ionic bond

## Workshop info

Subject:	Chemistry
Grades:	1 <sup>st</sup> - 2 <sup>nd</sup> class of high school
Class size:	10 to 16 students / 2 to 3 students per group
Duration:	1 day intro into 3D printing, 2 days of workshop
Skills needed:	None

## References and models

- <https://www.thingiverse.com/thing:1377130>

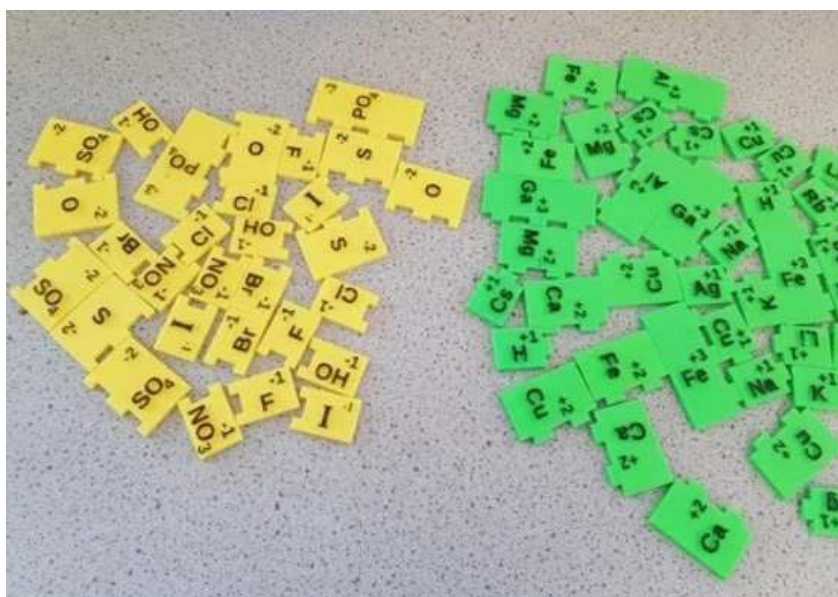

## Needed materials

In addition to a computer and a fused deposition 3D printer with the associated software, the following materials are needed for the workshop:

- FreecAD (free and open-source CAD modeler or a similar program)
- available models

## Learning objective

Ionic bond is the primary chemical bond between atoms and the creation of a 3D model of cations and anions is a great example of how to get students interested in the field of chemistry. The students work together in small groups where they create ion models.

Positive and negative ion models are made on 3D printers. Students are introduced to the basics of 3D printing, how the production process works and the difference between the printing processes. They learn to work independently with the printer and the associated ion model printing software.

## Basics of 3D printing (introductory lesson unit)

The teacher explains to the students how a 3D printer works, which types of printer they have, and how to handle the machine.

Some keywords the teacher should mention/explain:

- Printing process
- Layer height
- Infill / Infill Pattern
- File format
- Shell / Layer
- Design rules
- Support
- Slicer
- Raft
- Errors



## Lesson plan and activities

### 1. Teacher preparations

Each group of students should have a 3D models of the ions to print before they begin the process of selecting the necessary parameters for 3D printing. Initially, the students need to be explained the basics of ionic bonds, and let students also decide for themselves what examples of ions they want to print (the first day of the workshop). Have students think about the ratio of the number of ion charges in regard to the slots and the size of the ion models that will suit them.

**TIP:** Print ion models, positive in one color and negative in different colors and, if necessary, without supporting material, lying flat on the work platform. Additionally, name your models with letters and charge in a different color (if the printer settings allow it or using a marker) to make them more visible.

### Print settings

Raft	Yes
Support	No
Nozzle diameter	0.4 mm
Layer	0.19 mm
Infill	20%

### Model examples:

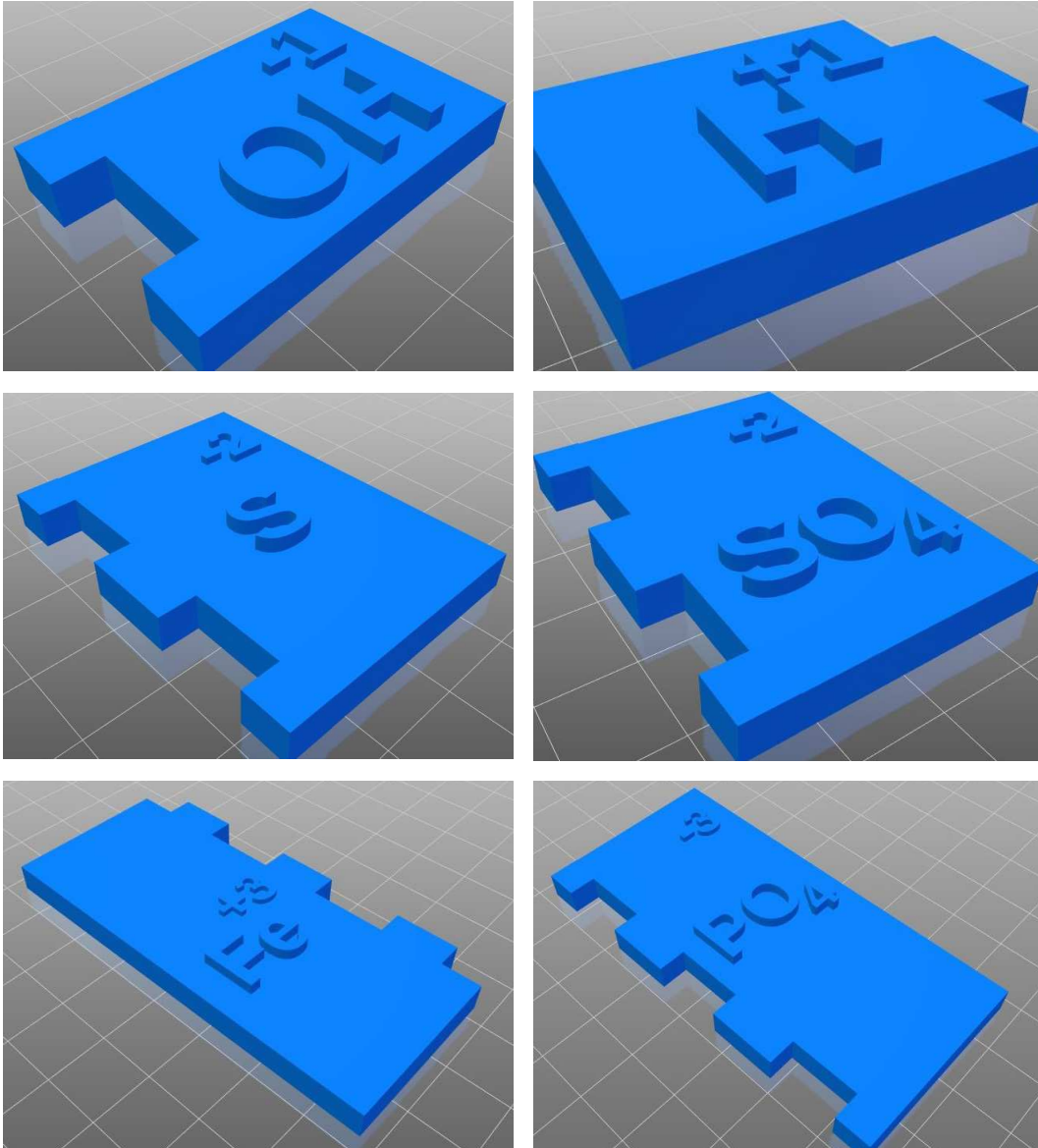

## 2. Basics of the ionic bond, description and demonstration

On the first day of the workshop, after the introductory lecture on 3D printing, the teacher explains to the students the basics of the ionic bond.

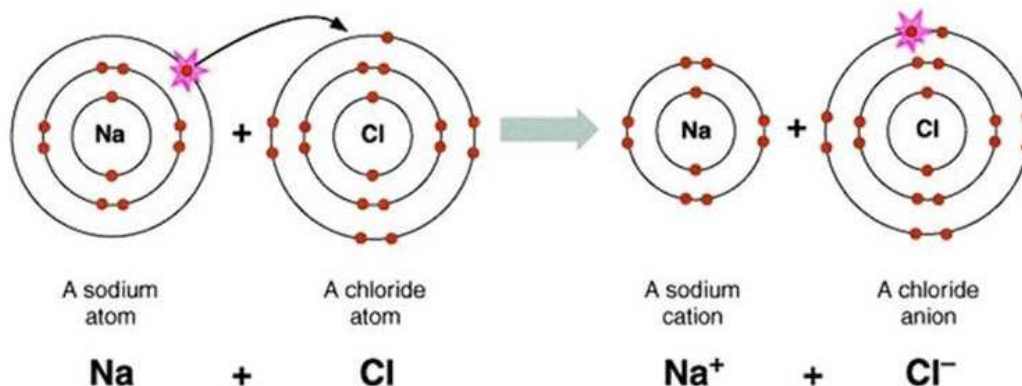

(Tes.com, 2019)

An ionic bond is the primary chemical bond between two atoms, most commonly between a metal atom and a non-metal in which the metal atom transfers its outer (valence) electron to the non-metal atom to create a more stable configuration. The metal atom becomes positively charged (cation), while the non-metal atom becomes negatively charged (anion). Ionic bonds are strong atomic bonds under the action of a Coulomb force whose strength decreases with the distance of the ions. The cations have a much smaller diameter than the anions.

For an ionic bond to work, the two atoms involved must have very different electronegativity values. Electronegativity is a measure of how strongly a particular atom attracts electrons, or how much it "wants" to fill its outer shell. Atoms with low electronegativity easily give up electrons, while atoms with high electronegativity easily take over electrons. Typically two atoms must have an electronegativity difference of more than 1.7 to form an ionic bond.

The valence shell is the farthest shell of the electrons that surrounds an atom. The number of electrons in this shell is important in determining how an atom will react and how much charge an ion might possess.

The cation and anion are attracted to each other in ionic compounds and each cation is surrounded by anions and vice versa. In ionic compounds, as well as in the most famous example of ionic bonds - sodium chloride, isolated molecules cannot be recognized. Each sodium cation in sodium chloride is surrounded by six chlorine anions and vice versa. The bonds between the sodium cations and all six chlorine anions are exactly the same. The formula to represent the ionic compound corresponds to the smallest numerical ratio of cations and anions in the compound observed. Therefore, we talk about a formula of sodium chloride, not a molecule.

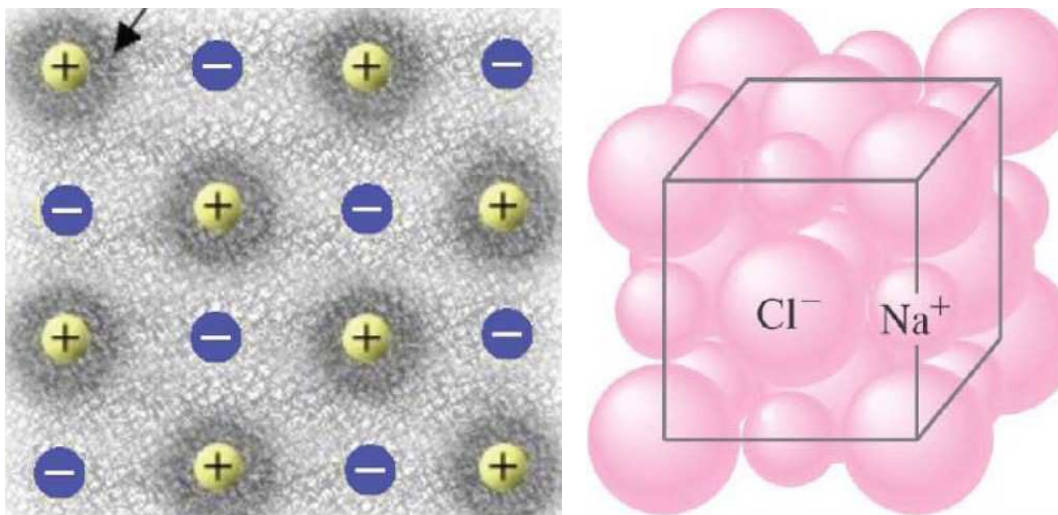

### 3. Test of the assembly designs of ionic bond models

Students must assemble the correct (!) ion bonding models from the models available to them.

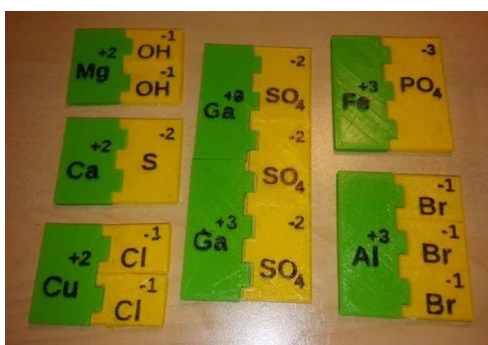

### 4. Evaluate and review

Each group presents elaborated examples of ionic bonds. Discuss what all chemistry topics and models can be made this way. What factors influence how you model such link examples. How can we improve, change or create our own model designs.

### 5. Modification of the original printing settings and testing of the new parts

In groups, students discuss which print settings they want to change and what impact on the printed object will it have. The modified parts were printed out and tested by the students. The modified print settings are for example to decrease the layer height from 0.19 mm to 0.14 mm to get a smoother surface. Know that this will increase the printing time. The infill is another parameter that the students can modify. They can change it from the recommended 20% to 30% or 40%. Use a scale to measure the weight difference of the new parts.

**TIP:** Modify printing setting one by one to see the effect. Keep in mind that a lower infill and number of slides will reduce the weight but also reduce the stability.

## 6. Evaluate and review the modified parts and whole model

Each group calculates and evaluates the main printing parameters such as: layer thickness, printing time, infill, layer height and other printing process characteristics. Discuss which parameters have the major impact for achieving the stability of the object. Determine if the expected results occurred.

## 7. Advanced part - designing and building new modified parts or the whole model

The next part of the workshop is that the students design and build their own designs of chemical bonds.

For that, the students model their own designs by using the knowledge they got through the workshop, the discussions and test of the model parts and shapes. They have two possible options. The first one is to modify the existing design. The second option is to create a complete new design. The groups can decide which options they want to choose and begin planning their design. The models can be examples of other types of chemical bonds.

## 8. Evaluation and review of the modified design

The students print their self-made designs and test them. Determine if the changes/improvements helped as expected.

## 9. Reflections

What chemical bond designs were the most efficient and what common design links do they have?

What's the most important thing you learned today? Why do you think so?

Would you use 3D printing for further projects?

What do you want to learn more about, and why?

Reflect on your thinking, learning, and work today. What were you most proud of?





**3D FOR VET**

STRATEGIC PARTNERSHIP FOR THE  
DEVELOPMENT OF 3D COMPETENCES

# **Student workshop: Covalent bond**

The European Commission's support for the production of this publication does not constitute an endorsement of the contents, which reflect the views only of the authors, and the Commission cannot be held responsible for any use which may be made of the information contained therein.



Erasmus+

# Contribution

## Responsible partner

- Metris Research Centre, Croatia

## Coordination

- Region of Istria, Croatia
- Regional Coordinator for European Programmes and Funds of the Region of Istria, Croatia

## Task Force / Project Partners

- Regional Coordinator for European Programmes and Funds of the Region of Istria, Croatia
- Carinthia University of Applied Sciences, Austria
- Pula Technical School, Croatia
- Metris Research Centre, Croatia
- Malopolska Voivodship, Poland
- Public Institution Panevėžys Vocational Education and Training Centre, Lithuania
- Jan Pawel II's School Miechow, Poland





# Student workshop: Covalent bond

## Workshop info

Subject:	Chemistry
Grades:	1 <sup>st</sup> - 2 <sup>nd</sup> class of high school
Class size:	10 to 16 students / 2 to 3 students per group
Duration:	1 day intro into 3D printing, 2 days of workshop
Skills needed:	None

## References and models

- <https://www.thingiverse.com/thing:1699927>



## Needed materials

In addition to a computer and a fused deposition 3D printer with the associated software, the following materials are needed for the workshop:

- FreeCAD (free and open-source CAD modeler or a similar program)
- available models

## Learning objective

Covalent bond is the primary chemical bond between non-metal atoms and the creation of a 3D model of atoms and bonds is a great example of how to get students interested in the field of chemistry. The students work together in small groups where they create atom and bond models.

Atom and bond models are made on 3D printers. Students are introduced to the basics of 3D printing, how the production process works and the difference between the printing process. They learn to work independently with the printer and the associated ion model printing software.

## Basics of 3D printing (introductory lesson unit)

The teacher explains to the students how a 3D printer works, which types of printer they have, and how to handle the machine.

Some keywords the teacher should mention/explain:

- Printing process
- Layer height
- Infill / Infill Pattern
- File format
- Shell / Layer
- Design rules
- Support
- Slicer
- Raft
- Errors

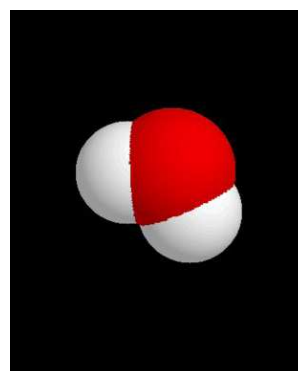
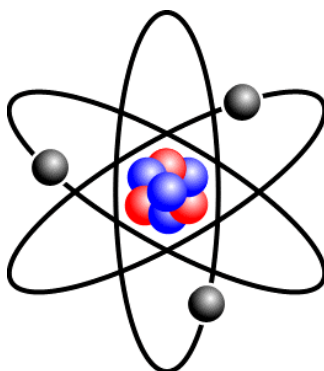

## Lesson plan and activities

### 1. Teacher preparations

Each group of students should have a basic 3D model of the basic elements of the molecule before they begin the process of selecting the necessary parameters for 3D printing. It is necessary to first explain to the students the basics of covalent bonds, let the students also decide for themselves which examples of atoms to combine into molecules and print (the first day of the workshop, let the students see examples of kits for organic chemistry). Have students think about atoms and the number of common electron pairs in a particular molecule and the size of the non-metal atom models themselves that will suit them.

**TIP:** Print individual atoms with one color (each atom of the same element in a molecule with one color; commonly hydrogen-white, oxygen-red, carbon-black, nitrogen-blue, chlorine-green...) and elements that connect atoms with a different color and, if necessary, without supporting material, lying flat on the work platform.

## Print settings

Raft	Yes
Support	Yes/No
Nozzle diameter	0.4 mm
Layer	0.29 mm
Infill	10%

## Model examples:

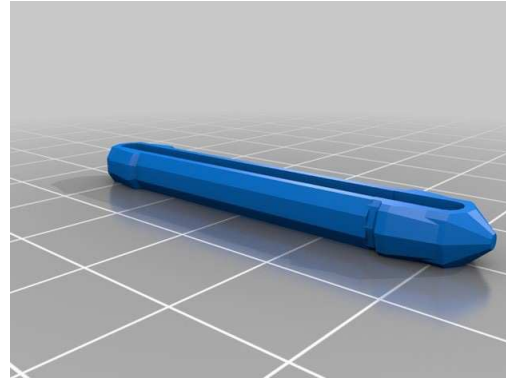
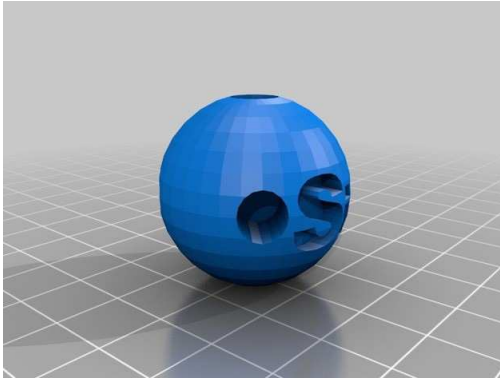

## 2. Basic structure of the covalent bond

On the first day of the workshop, after an introductory lecture on 3D printing, the teacher explains to the students the basics of covalent bonding.

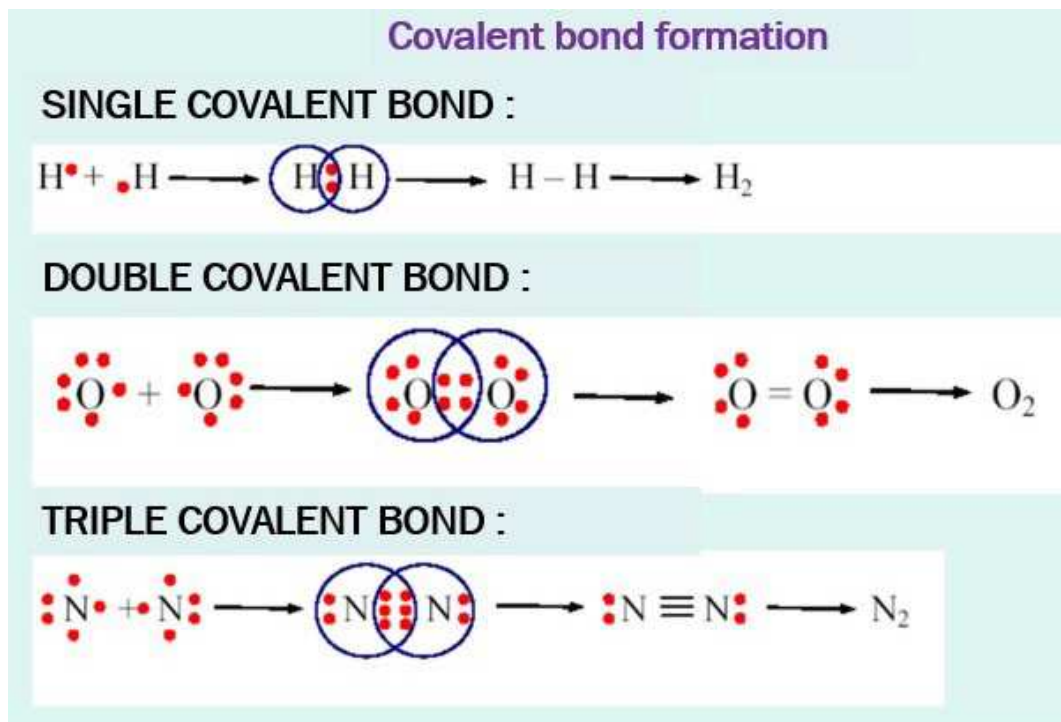

A covalent bond is formed when electrons divide between atoms and there is no electron transfer characteristic of the formation of an ionic bond. This creates molecules - particles made up of interconnected atoms. A covalent bond is a chemical bond that forms common electron pairs between non-metal atoms.

Molecules have a well-defined and constant composition and are often defined as the smallest part of a covalent compound that can participate in a chemical reaction.

A molecule is the smallest elementary particle of a simple or complex pure chemical substance that still has chemical properties for that substance. A molecule consists of atoms, equal in elemental matter, and different in chemical compounds. The molecule is, in principle, electrically neutral, with a paired number of electrons, although at times molecules are also considered to be ions and free radicals (which are electrically charged). The atoms in the molecule are held together by chemical bonds. The number of atoms in a molecule can be very different, for example an oxygen molecule consists of 2 atoms ( $O_2$ ), carbon dioxide of 3 atoms ( $CO_2$ ), and so on, up to millions of atoms (for example, a virus molecule). The molecular formula shows which atoms and to what extent they form a molecule, and the relative molecular mass. The bonding of atoms in a molecule is shown by a structural formula, and the spatial arrangement of atoms in a molecule is a stereochemical formula (chemical formula).

In atomic theory of matter, an atom consists of an atomic nucleus around which electrons (the electron envelope of an atom) orbit. It is generally accepted today that the atomic nucleus of all chemical elements consists of positively charged protons and neutrons that do not have an electrical charge. Particles contained in an atomic nucleus, that is, protons and neutrons, are collectively called nucleons. A neutron has a mass almost equal to that of a proton. A proton is the nucleus of a hydrogen atom, so its mass is equal to the mass of a hydrogen atom. The number of protons in an atomic nucleus called an atomic number is equal to its electric charge and always corresponds to the ordinal number of the chemical element in the periodic system. So the atomic number determines the type of chemical element.

The size of the molecule depends on the number, type and arrangement of the atoms and is generally in the range of 0.1 to 10 nanometers, while the mass is usually between  $10^{-24}$  and  $10^{-20}$  grams. The mass of huge molecules (macromolecules), which can sometimes be seen with an electron microscope, is much larger (about  $10^{-18}$  grams). The existence of smaller molecules is manifested in many phenomena such as diffusion, Brown motion, volumetric ratios for gas coupling, thermal radiation, light scattering in the atmosphere, deflection or diffraction of X-rays, and more. More detailed information on the molecular structure of the experiments (experimentally) is obtained by their interaction with electromagnetic radiation (spectroscopy).

A covalent bond joins non-metal atoms that bond together to achieve the electronic configuration of the noble gas, or octet. Each atom gives one electron and they create a common electron pair (covalence) which can be one or more between two atoms. Common electron pairs belong to both atomic nuclei and connect both atoms. The covalent bond is directed in space (molecules have a defined shape) and does not conduct electricity.

### 3. Test of the assembly designs of covalent bond models

Students must assemble correct (!! ) models of covalent bonds, i.e. organic molecules – combinations of available atoms and their bonds from the models available to them.

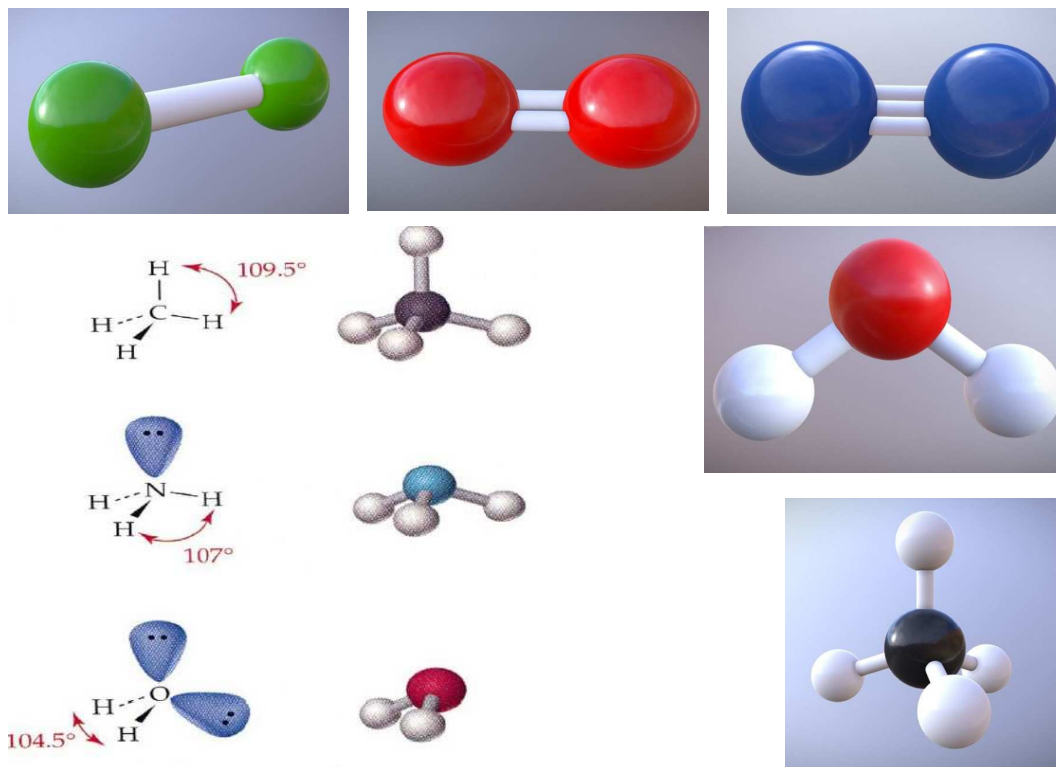

### 4. Evaluate and review

Each group presents an elaborate example of the molecule. Discuss what all chemistry topics and models can be crafted this way. What factors affect how a molecule is modeled. How can we improve, change or create our own molecule model design.

### 5. Modification of the original printing settings and testing of the new parts

In groups, students discuss which print settings they want to change and what impact on the printed object will it have. The modified parts were printed out and tested by the students. The modified print settings are for example to decrease the layer height from 0.29 mm to 0.14 mm to get a smoother surface. Know that this will increase the printing time. The infill is another parameter that the students can modify. They can change it from the recommended 10% to 20% or 40%. Use a scale to measure the weight difference of the new parts.

**TIP:** Modify printing setting one by one to see the effect. Keep in mind that a lower infill and number of slides will reduce the weight but also reduce the stability.

## 6. Evaluate and review the modified parts

Each group calculates and evaluates the main printing parameters such as: layer thickness, printing time, infill, layer height and other printing process characteristics. Discuss which parameters have the major impact for achieving the stability of the object. Determine if the expected results occurred.

## 7. Advanced part - Designing and building new modified parts

The next part of the workshop is that the students design and build their own designs of the molecules.

For that, the students model their own designs by using the knowledge they got through the workshop, the discussions and test different shapes. They have two possible options. The first one is to modify the existing design. The second option is to create a complete new design. The groups can decide which options they want to choose and begin planning their design.

### Different examples:

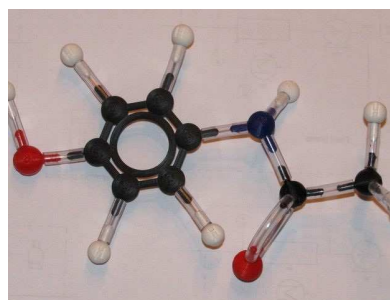
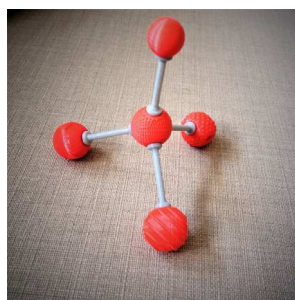
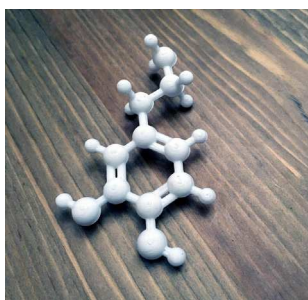

## 8. Evaluation and review of the modified design

The students print their self-made designs and test them. Determine if the changes/improvements helped as expected.

## 9. Reflections

What atom and bond designs were the most efficient and what common design links do they have?

What's the most important thing you learned today? Why do you think so?

Would you use 3D printing for further projects?

What do you want to learn more about, and why?

Reflect on your thinking, learning, and work today. What were you most proud of?